











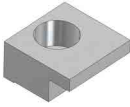





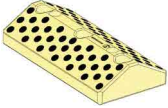
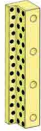

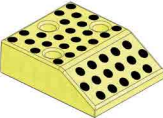

Die Components Normalien Componenti

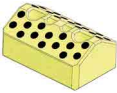

OMCR[®]
STANDARD DIE COMPONENTS

F33010001÷0049	F33010038÷0059	F33020019÷0026	F33020036÷0037	F33030001÷0040
				
Guide post Führungssäule Colonna guida	Guide post Führungssäule Colonna guida	Bush self-lubricating Führungsbuchse Boccola autolubrificante	Toe clamp Haltestück Ritegno	Matrix Retainer Aufnahmeplatte Portamatrice
440	441	442	442	443
F33030041÷0070	F3304000÷0138	F33040121÷F33050012	F33040084÷0164	F33040090÷0093
				
Distance Plate Druckplatte Distanziale	Wear plate VDI 3357 Gleitplatte VDI 3357 Piastra guida VDI 3357	Wear plate VDI 3357 Gleitplatte VDI 3357 Piastra guida VDI 3357	Cam positive return follower Gleitstück Reazione gancio	"V" driver VDI 3357 Prismenführung mit festschmierstoff VDI 3357 Guida a "V" VDI 3357
444	445	446	447	448
F33040100÷0111	F33040139÷0147	F33040148÷0156	F33040287÷0289	F33040288÷0290
				
Angular guide Winkelleiste Guida angolare	Cam dwell wear plate steel Überlaufkeile stahl Cuneo in acciaio	Cam dwell wear plate self-lubricating Überlaufkeile bronze mit festschmierstoff Cuneo autolubrificante	Positive Return Zwangsrückholer Gancio	Positive Return Zwangsrückholer Gancio
449	450	451	452	452
F33040305÷0320	F33050069÷0072	F33050087	F33050088	F33050089÷0100
				
Wear plate Gleitplatte Piastra guida	"V" driver VDI 3357 Prismenführung VDI 3357 Guida a "V" VDI 3357	"V" driver Prismenführung Guida a "V"	"V" driver self-lubricating Prismenführung bronze mit festschmierstoff Guida a "V" autolubrificante	Wear plate Gleitplatte Piastra guida
453	454	455	455	456

F33050101÷0107	F33150011÷0015	F33150037÷0044	F33150045÷0048	F33150060-0061
				
Wear plate Gleitplatte Piastra guida 456	Pad Retainer Steckbolzen Perno di arresto 457	Aerial Pin Luftbolzen Candela 457	Upper air cushion pin Oberluftbolzen Candela superiore 458	Locating Pin Zentrierbolzen Centraggio 458
F33150087÷0091	F33160106÷0107	F33160157÷0188	F33160218	F33160230÷0250
				
Lifting pin Tragbolzen mit Fallringsicherung Perno di sollevamento 459	Fixing plate Befestigungsplatte Piastra di fissaggio 460	Shim plate Ausgleichbleche Piastra di spessoramento 461	Fastening plates Halteplatte Piastre di ritegno 462	Shim punch retainer Druckplatte Spessore per portapunzone 462
F33160226÷0344	F33160345÷0371	F33180007÷0012	F33190003 ÷0038	F33190005-0026
				
Striker plate Distanzkappe Reazione per cilindro 463	Striker plate Distanzkappe Reazione per cilindro 464	Washer Scheibe Rondella 465	Locating Cone Kegeldistanz Cono di centraggio 466	Spacer Distanzstück Distanziale 466
F33190031÷0034	F33190035÷0036	F33200009÷0033	F33220332÷0343	F33260004-0397
				
Bottoming block Abstandblock Distanziale 467	Spacer Distanzstück Distanziale 467	Key Passfeder Chiavetta 468	Roller cam unit Rollenschieber Camma a rullo 469	Gage Einweiser Riferimento 470

F33260014-0024	F33260032	F33260203-0205	F33260223-0342	F33290002
				
Acceleration cam Schiebervorbeschleunigung Camma di accelerazione	Cam roller Rollenbock Supporto con rullo	Front gage Einlaufanschlag Portasensore	Slide stop block Schieberanschlag Arresto slitta	Stamp rack pillar Markierstempelkonsole Colonna portatimbri
470	471	471	472	473
F33290041	F33290043-0164	F33290063	F33290068	F33910001
				
Counter-pressure plate Gegendruckplatte Piastrina di reazione	Stamp Buchstabenstempel Marchio	Stamp Buchstabenstempel Marchio	Visual locator punch Endkontrollstempel Punzone di visualizzazione	Air coupling bracket Luftanschlussblock Supporto innesti rapidi
473	474	474	475	476
F33910002	F33910003	F33910043	F33910044	F33910110-0115
				
Air coupling bracket Luftanschlussblock Supporto innesti rapidi	Air coupling bracket Luftanschlussblock Supporto innesti rapidi	Retainer for stamps Halteplatte Portatimbri	Retainer for stamps Halteplatte Portatimbri	Bush for lifting pin Buchse für Tragbolzen Boccola per perno di sollevamento
476	476	477	477	478
J06910069-70	M16045182-184	M36600070-0073		
				
Sensor mounting brackets Sensorhalterungen Staffa per sensore	Shock absorber Halteelement Ammortizzatore	Washer Scheibe Rondella		
478	479	479		



GUIDE POST - FÜHRUNGSSÄULE - COLONNA GUIDA



Notes

Material: Steel
HRC: 60÷62

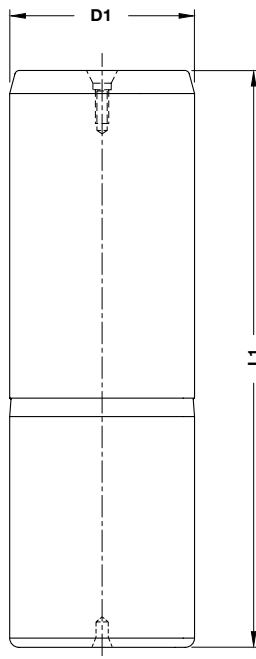

	OPEL CODE
	F3301002

OPEL CODE	D1	L1	OPEL CODE	D1	L1	OPEL CODE	D1	L1
F33010001	25	125	F33010015	40	280	F33010029	63	315
F33010002	25	140	F33010016	50	160	F33010030	63	355
F33010003	25	160	F33010017	50	180	F33010031	63	400
F33010004	25	180	F33010018	50	200	F33010032	80	224
F33010005	32	140	F33010019	50	224	F33010033	80	250
F33010006	32	160	F33010020	50	250	F33010034	80	280
F33010007	32	180	F33010021	50	280	F33010035	80	315
F33010008	32	200	F33010022	50	315	F33010036	80	355
F33010009	40	140	F33010023	50	355	F33010037	80	400
F33010010	40	160	F33010024	63	180	F33010046	63	450
F33010011	40	180	F33010025	63	200	F33010047	63	500
F33010012	40	200	F33010026	63	224	F33010048	80	450
F33010013	40	224	F33010027	63	250	F33010049	80	500
F33010014	40	250	F33010028	63	280			

GUIDE POST - FÜHRUNGSSÄULE - COLONNA GUIDA

Notes

Material: Steel

HRC: 60÷62

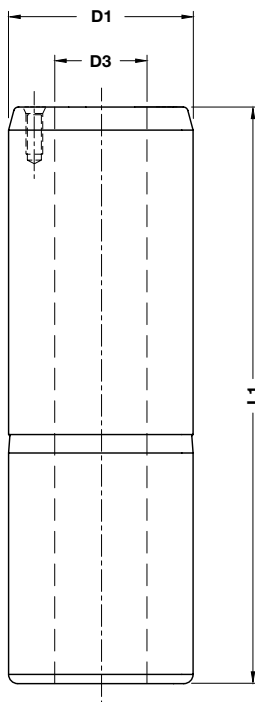

Standard Opel

	OPEL CODE
	F33010038

OPEL CODE	D1	D3	L1	OPEL CODE	D1	D3	L1
F33010038	100	50	280	F33010051	100	50	500
F33010039	100	50	315	F33010052	100	50	550
F33010040	100	50	355	F33010053	100	50	600
F33010041	100	50	400	F33010054	100	50	650
F33010042	125	65	315	F33010055	125	65	500
F33010043	125	65	355	F33010056	125	65	550
F33010044	125	65	400	F33010057	125	65	600
F33010045	125	65	450	F33010058	125	65	650
F33010050	100	50	450				

BUSH SELF-LUBRICATING - FÜHRUNGSBUCHSE - BOCCOLA AUTOLUBRIFICANTE

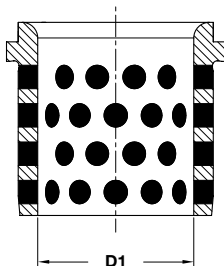

Notes

Material: Bronze + Graphite
HB > 190

STOCK



OPEL CODE
 F33020020

OPEL CODE	D1
F33020019	25
F33020020	32
F33020021	40
F33020022	50
F33020023	63
F33020024	80
F33020025	100
F33020026	125

TOE CLAMP - HALTESTÜCK - RITEGNO PER BOCCOLA

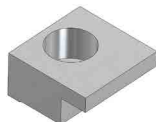

Notes

Material: CK45

Application example

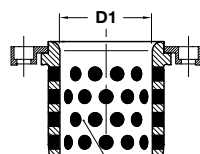

F33020019-F33020026

STOCK



OPEL CODE
 F33020037

OPEL CODE	D1
F33020036	25-50
F33020037	63-125

MATRIX RETAINER - AUFNAHMEPLATTE - PORTAMATRICE

Notes

Material: CK45

STOCK

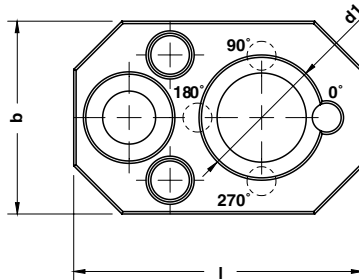
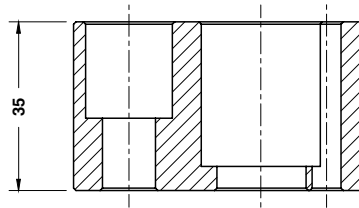
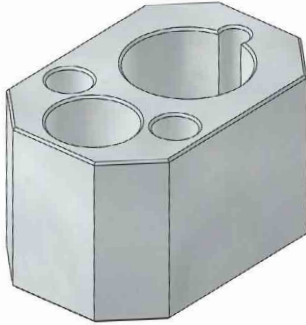

Standard Opel

ORDER EXAMPLE	OPEL CODE
	F3303002

OPEL CODE				b	d1	l
DOWEL PIN LOCATION						
0°	90°	180°	270°			
F33030001	F33030011	F33030021	F33030031	40	10	60
F33030002	F33030012	F33030022	F33030032	40	13	60
F33030003	F33030013	F33030023	F33030033	40	16	60
F33030004	F33030014	F33030024	F33030034	40	20	60
F33030006	F33030016	F33030026	F33030036	40	25	60
F33030007	F33030017	-	F33030037	40	32	60
F33030008	F33030018	F33030028	F33030038	60	38	80
F33030009	F33030019	F33030029	F33030039	60	45	80
F33030010	F33030020	-	F33030040	60	50	80

DISTANCE PLATE - DRUCKPLATTE - DISTANZIALE

Notes

Material: CK45

STOCK

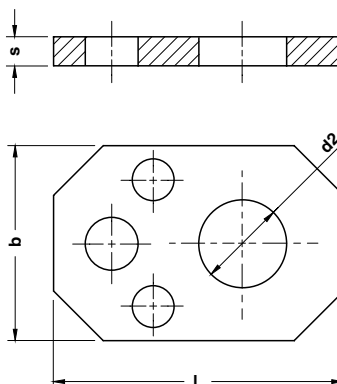
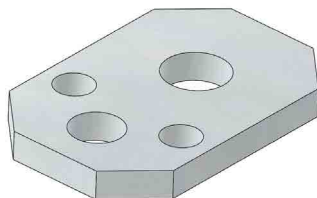

ORDER EXAMPLE	OPEL CODE
	F33030042

OPEL CODE	b	d2	l	s	OPEL CODE	b	d2	l	s
F33030041	40	6,5	60	2	F33030058	40	19	60	6
F33030042	40	6,5	60	4	F33030059	40	22,5	60	2
F33030043	40	6,5	60	6	F33030060	40	22,5	60	4
F33030044	40	9,5	60	2	F33030061	40	22,5	60	6
F33030045	40	9,5	60	4	F33030062	60	28,5	80	2
F33030046	40	9,5	60	6	F33030063	60	28,5	80	4
F33030047	40	11	60	2	F33030064	60	28,5	80	6
F33030048	40	11	60	4	F33030065	60	37,5	80	2
F33030049	40	11	60	6	F33030066	60	37,5	80	4
F33030050	40	13,5	60	2	F33030067	60	37,5	80	6
F33030051	40	13,5	60	4	F33030068	60	42,5	80	2
F33030052	40	13,5	60	6	F33030069	60	42,5	80	4
F33030056	40	19	60	2	F33030070	60	42,5	80	6
F33030057	40	19	60	4					

WEAR PLATE SELF-LUBRICATING VDI 3357
GLEITPLATTE BRONZE MIT FESTSCHMIERSTOFF VDI 3357
PIASTRA GUIDA AUTOLUBRIFICANTE VDI 3357

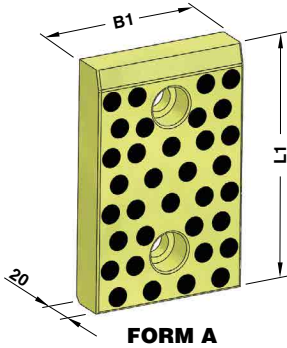

FORM A

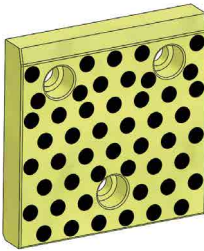

FORM B

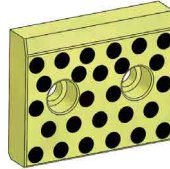

FORM C

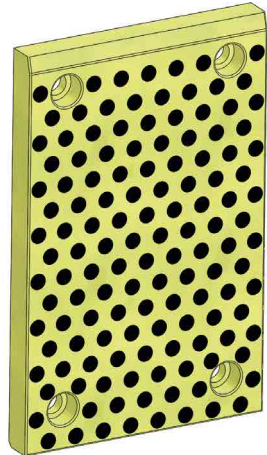

FORM D

Notes
Material: Bronze + Graphite
HB > 190



Standard Opel

ORDER EXAMPLE	OPEL CODE
	F33040001

* Not in accordance with VDI3357
 Nicht mit Entspricht VDI3357
 Non conforme alla norma VDI3357

OPEL CODE	B1	L1	FORM	OPEL CODE	B1	L1	FORM
F33040000	50	100	A	F33040015	125	100	B
F33040001	50	125	A	F33040016	125	125	B
F33040002	50	160	A	F33040017	125	160	B
F33040003	50	200	A	F33040018	160	100	B
F33040004	80	100	A	F33040019	160	125	B
F33040005	80	125	A	F33040020	160	160	B
F33040006	80	160	A	F33040113*	100	250	D
F33040007	80	200	A	F33040114*	125	200	D
F33040008	100	50	C	F33040115*	160	200	D
F33040009	100	80	C	F33040116*	160	250	D
F33040010	100	100	A	F33040117*	160	300	D
F33040011	100	125	A	F33040118*	200	200	D
F33040012	100	160	A	F33040119*	200	250	D
F33040013	100	200	A	F33040120*	200	300	D
F33040014	125	80	C	F33040138*	125	250	D

WEAR PLATE STEEL VDI 3357
GLEITPLATTE STAHL VDI 3357
PIASTRA GUIDA IN ACCIAIO VDI 3357

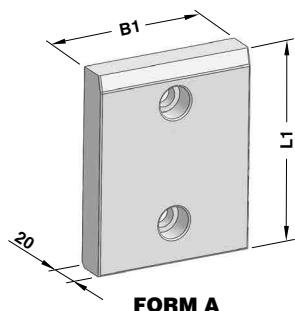

FORM A

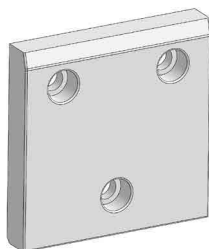

FORM B

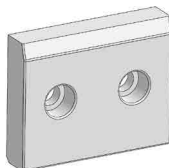

FORM C

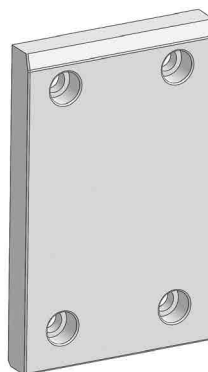

FORM D

Notes

Material: 16MnCr5

HRC: 58÷60

STOCK



	OPEL CODE
	F33040121

* Not in accordance with VDI3357
 entspricht nicht VDI3357
 Non conforme alla norma VDI3357

OPEL CODE	B1	L1	FORM	OPEL CODE	B1	L1	FORM
F33040121	100	50	C	F33040136*	200	250	D
F33040122	100	80	C	F33040137*	200	300	D
F33040123*	100	250	D	F33050000	50	100	A
F33040124	125	80	C	F33050001	50	125	A
F33040125	125	100	B	F33050002	50	160	A
F33040126	125	125	B	F33050003	50	200	A
F33040127*	125	200	D	F33050004	80	100	A
F33040128*	125	250	D	F33050005	80	125	A
F33040129	160	100	B	F33050006	80	160	A
F33040130	160	125	B	F33050007	80	200	A
F33040131	160	160	B	F33050008	100	100	A
F33040132*	160	200	D	F33050009	100	125	A
F33040133*	160	250	D	F33050010	100	160	A
F33040134*	160	300	D	F33050011	100	200	A
F33040135*	200	200	D	F33050012	125	160	B

CAM POSITIVE RETURN FOLLOWER GLEITSTÜCK REAZIONE GANCIO

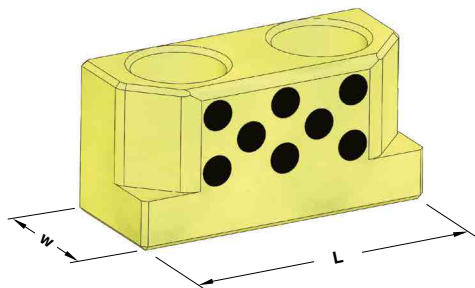

Notes

Material: Bronze + Graphite
HB > 190



ORDER EXAMPLE	OPEL CODE
	F33040163

OPEL CODE	L	W
F33040084	60	25
F33040163	60	32
F33040164	80	32

WEAR PLATE SELF-LUBRICATING GLEITPLATTE MIT FESTSCHMIERSTOFF PIASTRA GUIDA AUTOLUBRIFICANTE

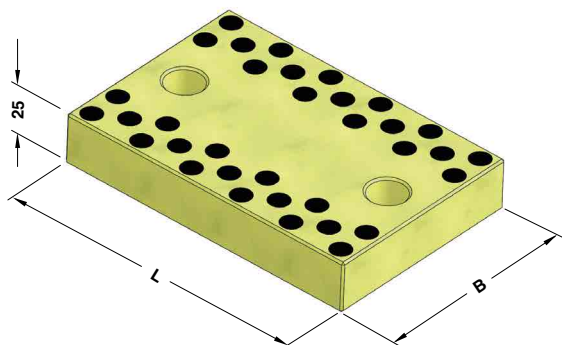

Notes

Material: Bronze + Graphite
HB > 190



ORDER EXAMPLE	OPEL CODE
	F33040086

OPEL CODE	B	L
F33040085	100	100
F33040086	100	150
F33040112	120	150

"V" DRIVER SELF-LUBRICATING VDI 3357
PRISMENFÜHRUNG BRONZE MIT FESTSCHMIERSTOFF VDI 3357
GUIDA A "V" AUTOLUBRIFICANTE VDI 3357

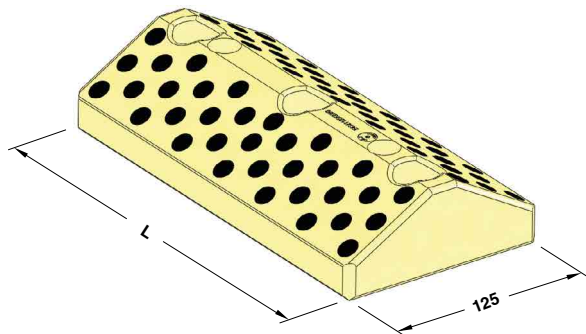

Notes

Material: Bronze + Graphite
HB > 190

STOCK

	OPEL CODE
	F33040091

OPEL CODE	L
F33040090	150
F33040091	200
F33040092	250
F33040093	300

ANGULAR GUIDE - WINKELLEISTE - GUIDA ANGOLARE

Notes

Material: Bronze + Graphite
HB > 190

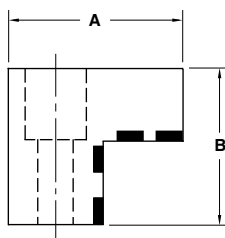
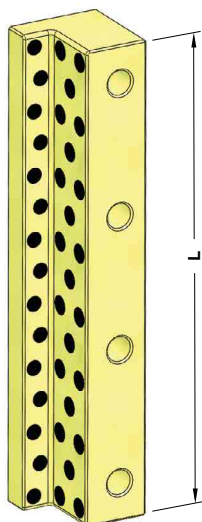

FORM A

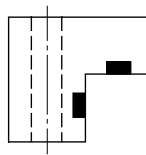

FORM B

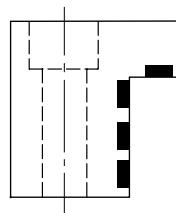

FORM C

ORDER EXAMPLE	OPEL CODE
	F33040101

OPEL CODE	A	B	L	FORM	OPEL CODE	A	B	L	FORM
F33040100	50	45	200	A	F33040106	32	30	150	B
F33040101	50	45	250	A	F33040107	32	30	250	B
F33040102	50	45	300	A	F33040108	32	30	300	B
F33040103	50	45	350	A	F33040109	50	50	200	C
F33040104	50	45	400	A	F33040110	50	50	250	C
F33040105	50	45	500	A	F33040111	50	50	300	C

CAM DWELL WEAR PLATE STEEL
UBERLAUFKEILE STAHL
CUNEO IN ACCIAIO

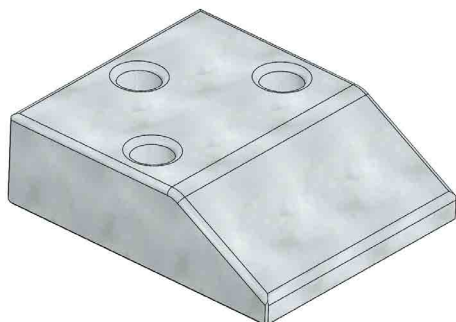

Notes

Material: 42CrMo4
HRC: 58÷60

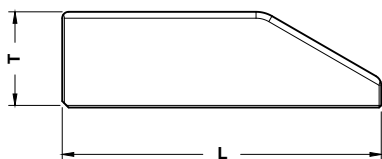
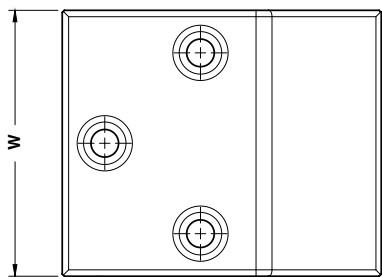

	OPEL CODE
	F33040140

OPEL CODE	L	T	W
F33040139	125	30	100
F33040140	125	30	125
F33040141	125	30	160
F33040142	150	45	100
F33040143	150	45	125
F33040144	150	45	160
F33040145	170	60	100
F33040146	170	60	125
F33040147	170	60	160

CAM DWELL WEAR PLATE SELF-LUBRICATING UBERLAUFKEILE BRONZE MIT FESTSCHMIERSTOFF CUNEO AUTOLUBRIFICANTE

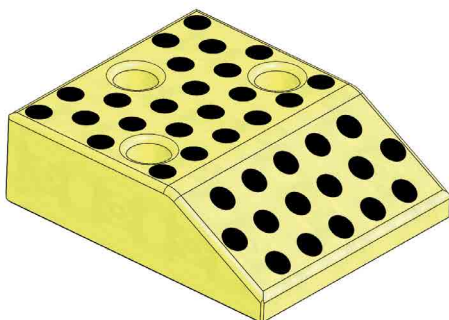

Notes
Material: Bronze + Graphite
HB > 190



Standard Opel

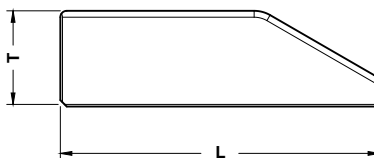
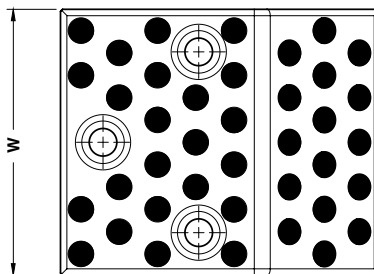

	OPEL CODE
	F33040149

OPEL CODE	L	T	W
F33040148	125	30	100
F33040149	125	30	125
F33040150	125	30	160
F33040151	150	45	100
F33040152	150	45	125
F33040153	150	45	160
F33040154	170	60	100
F33040155	170	60	125
F33040156	170	60	160

POSITIVE RETURN - ZWANGSRÜCKHOLER - GANCIO

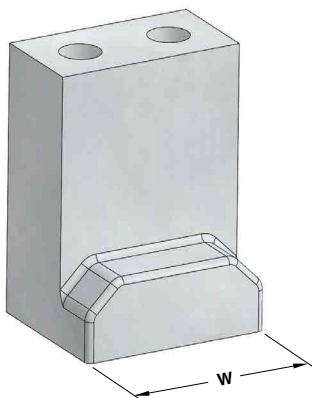

Notes

Material: C45

HRC: 58÷60

STOCK

	OPEL CODE
	F33040289

OPEL CODE	W
F33040287	60
F33040289	80

POSITIVE RETURN - ZWANGSRÜCKHOLER - GANCIO

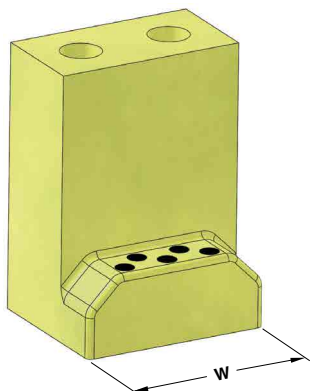

Notes

Material: Bronze + Graphite

HB > 190

STOCK

	OPEL CODE
	F33040290

OPEL CODE	W
F33040288	60
F33040290	80

**WEAR PLATE SELF-LUBRICATING VDI 3357
GLEITPLATTE BRONZE MIT FESTSCHMIERSTOFF VDI 3357
PIASTRA GUIDA AUTOLUBRIFICANTE VDI 3357**

Notes

Material: Bronze + Graphite
HB > 190

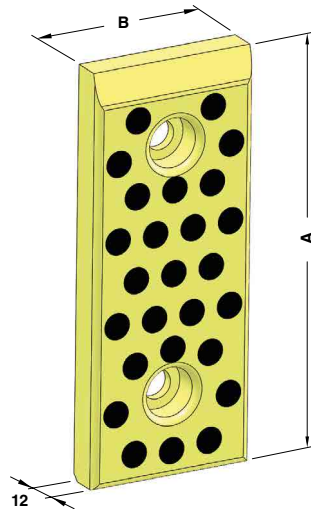

Standard Opel

	OPEL CODE
	F33040306

OPEL CODE	B	A	OPEL CODE	B	A
F33040305	30	80	F33040313	50	80
F33040306	30	100	F33040314	50	100
F33040307	30	125	F33040315	50	125
F33040308	30	200	F33040316	50	200
F33040309	40	80	F33040317	60	80
F33040310	40	100	F33040318	60	100
F33040311	40	125	F33040319	60	125
F33040312	40	200	F33040320	60	200

**"V" DRIVER STEEL VDI 3357
PRISMENFÜHRUNG STAHL VDI 3357
GUIDA A "V" IN ACCIAIO VDI 3357**

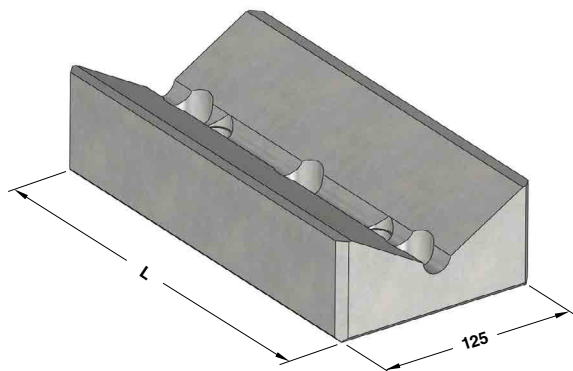

Notes

Material: CK45

HRC: 58÷60

STOCK



OPEL CODE

F33050070

OPEL CODE	L
F33050069	150
F33050070	200
F33050071	250
F33050072	300

"V" DRIVER STEEL - PRISMENFÜHRUNG - GUIDA A "V" IN ACCIAIO

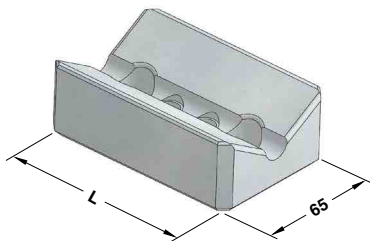

Notes

Material: CK45

HRC: 58÷60

STOCK



OPEL CODE

F33050087

OPEL CODE	L
F33050087	100

Standard Opel

**"V" DRIVER SELF-LUBRICATING
PRISMENFÜHRUNG BRONZE MIT FESTSCHMIERSTOFF
GUIDA A "V" AUTOLUBRIFICANTE**

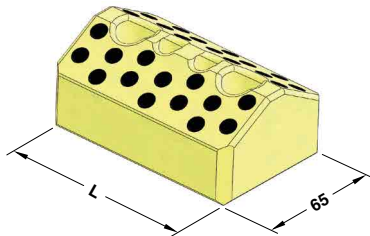

Notes

Material: Bronze + Graphite

HB > 190

STOCK



OPEL CODE

F33050088

OPEL CODE	L
F33050088	100

WEAR PLATE - GLEITPLATTE - PIASTRA GUIDA

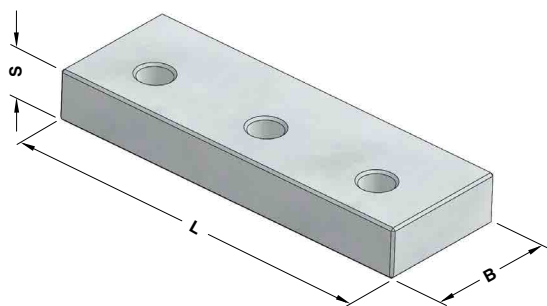

Notes

Material: CK45
HRC: 58÷60



OPEL CODE

F33050090

OPEL CODE	B	L	S	OPEL CODE	B	L	S
F33050089	52	150	20	F33050095	77	150	35
F33050090	52	200	20	F33050096	77	200	35
F33050091	52	250	20	F33050097	77	250	35
F33050092	72	150	30	F33050098	82	150	40
F33050093	72	200	30	F33050099	82	200	40
F33050094	72	250	30	F33050100	82	250	40

WEAR PLATE - GLEITPLATTE - PIASTRA GUIDA

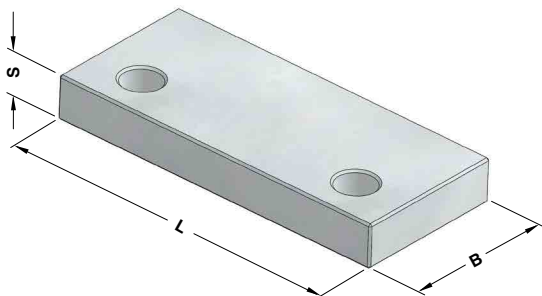

Notes

Material: CK45
HRC: 58÷60



OPEL CODE

F33050102

OPEL CODE	B	L	S	OPEL CODE	B	L	S
F33050101	70	160	25	F33050105	85	240	28
F33050102	70	200	25	F33050106	85	300	28
F33050103	70	240	25	F33050107	85	350	28
F33050104	85	200	28				

PAD RETAINER PIN - STECKBOLZEN - PERNO DI ARRESTO

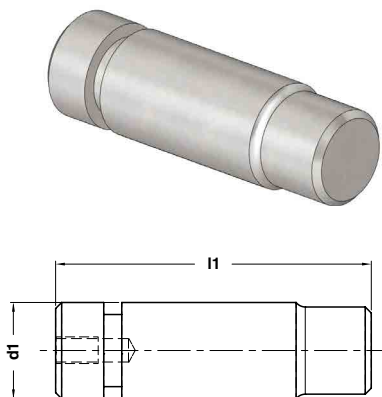

Notes

Material: 42CrMo4
900±1000 N/mm²

STOCK



OPEL CODE
F33150012

OPEL CODE	d1	l1
F33150011	32	130
F33150012	40	155
F33150013	50	185
F33150014	56	190
F33150015	63	210

Standard Opel

AERIAL PIN - LUFTBOLZEN - CANDELA

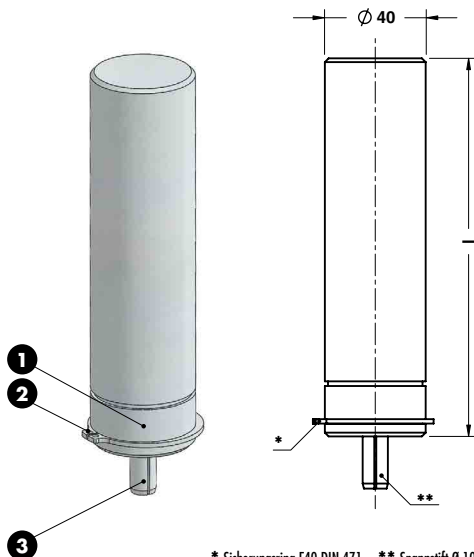

Notes

- 1 **Material:** CK45
- 2 E Ring E40 - DIN 471
- 3 Elastic Pin Ø10x35 - DIN 8752

STOCK



OPEL CODE
F33150038

OPEL CODE	l
F33150037	125
F33150038	150
F33150039	175
F33150040	200
F33150041	225
F33150042	250
F33150043	275
F33150044	300

* Sicherungsring E40 DIN 471 ** Spannstift Ø 10x35 DIN 8752
Anello elastico E40 DIN 471 Spina elastica Ø 10x35 DIN 8752

UPPER AIR CUSHION PIN - OBERLUFTBOLZEN - CANDELA SUPERIORE

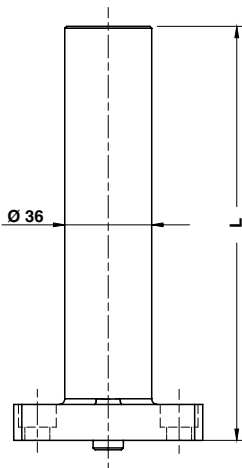
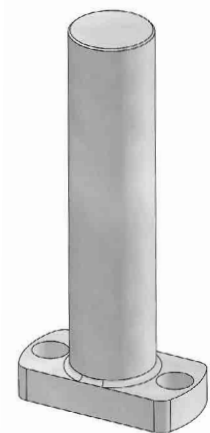

Notes

Material: CK45
800÷1000 N/mm²



OPEL CODE	
F33150046	

OPEL CODE	L
F33150045	150
F33150046	175
F33150047	200
F33150048	225

LOCATING PIN - ZENTRIERBOLZEN - CENTRAGGIO



Notes

Material: 16MnCr5
HRC: 56÷60



OPEL CODE	
F33150061	

OPEL CODE	d
F33150060	40
F33150061	50

LIFTING PIN OPEL-GM TRAGBOLZEN MIT FALLRINGSICHERUNG OPEL-GM NORM PERNO DI SOLLEVAMENTO OPEL-GM



Respect the max load
Maximale Nutzlast beachten
Rispettare il carico Max

WARNING - ACHTUNG - ATTENZIONE:

For safety reason, please consider always that the weight of the die has to be supported by just 2 lifting pins.

Aus Sicherheitsgründen stets berücksichtigen, dass zwei Tragbolzen das gesamte Werkzeuggewicht tragen müssen.

Per ragioni di sicurezza, considerare sempre che il peso dello stampo deve essere sopportato da 2 soli perni.

Notes

Material: 42CrMo4 + QT

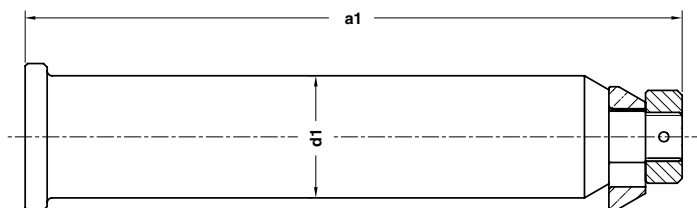

The part is supplied complete of steel spring

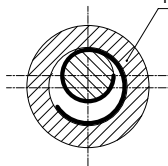

ORDER EXAMPLE	OPEL CODE
	F33150088

OPEL CODE	a1	d1	Max load (kg)	Max die weight (kg)
F33150087	177	32	3400	6800
F33150088	220	40	5650	11300
F33150089	270	50	8950	17900
F33150090	342	63	14350	28700
F33150091	387	80	26700	53400

FIXING PLATE - BEFESTIGUNGSPLATTE - PIASTRA DI FISSAGGIO

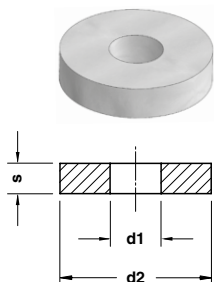

Notes
Material: CK45

STOCK

ORDER EXAMPLE
OPEL CODE
F33160107

OPEL CODE	d1	d2	s
F33160106	21	70	10
F33160107	25	80	15

SHIM PLATE - AUSGLEICHBLECHE - PIASTRA DI SPESSORAMENTO

Notes

Material: St37

STOCK

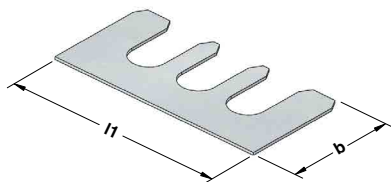

FORM A

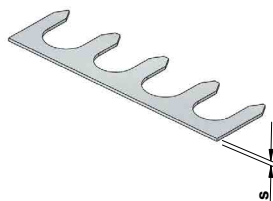

FORM B

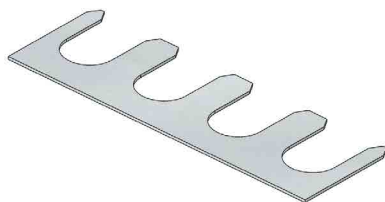

FORM C

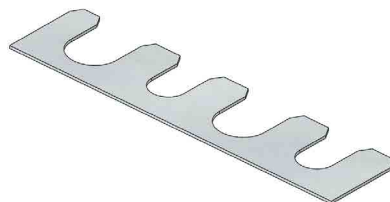



FORM D

	OPEL CODE
	F33160158

OPEL CODE	b	l1	s	FORM	OPEL CODE	b	l1	s	FORM
F33160157	20	60	0,5	C	F33160169	15	40	0,5	A
F33160158	20	60	1	C	F33160170	15	40	1	A
F33160159	20	60	2	C	F33160171	15	40	2	A
F33160160	20	45	0,5	A	F33160172	20	52	0,5	A
F33160161	20	45	1	A	F33160173	20	52	1	A
F33160162	20	45	2	A	F33160174	20	52	2	A
F33160163	15	45	0,5	A	F33160183	12,4	42	0,5	B
F33160164	15	45	1	A	F33160184	12,4	42	1	B
F33160165	15	45	2	A	F33160185	12,4	42	2	B
F33160166	20	40	0,5	A	F33160186	15,8	65	0,5	D
F33160167	20	40	1	A	F33160187	15,8	65	1	D
F33160168	20	40	2	A	F33160188	15,8	65	2	D

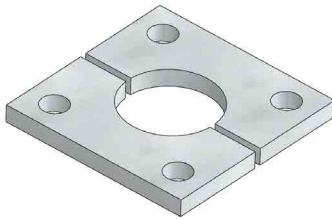
FASTENING PLATES - HALTEPLATTE - PIASTRE DI RITEGNO



Notes	
Material: St37	
STOCK	
	OPEL CODE
	F33160218
OPEL CODE	
F33160218	

SHIM PUNCH RETAINER - DRUCKPLATTE - SPESSORE PER PORTAPUNZONE

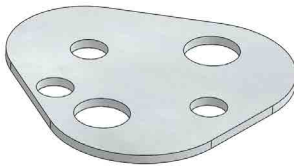

Notes	
Material: C20	
STOCK	

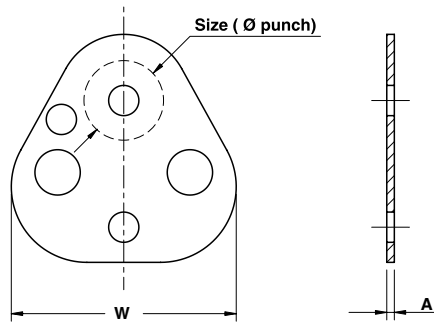

	OPEL CODE
	F33160231

OPEL CODE	A	W	Size	OPEL CODE	A	W	Size	OPEL CODE	A	W	Size
F33160230	2	43,7	10	F33160237	4	53,2	16	F33160244	6	69,1	25
F33160231	4	43,7	10	F33160238	6	53,2	16	F33160245	2	69,1	32
F33160232	6	43,7	10	F33160239	2	59,5	20	F33160246	4	69,1	32
F33160233	2	50,0	13	F33160240	4	59,5	20	F33160247	6	69,1	32
F33160234	4	50,0	13	F33160241	6	59,5	20	F33160248	2	76,7	40
F33160235	6	50,0	13	F33160242	2	69,1	25	F33160249	4	76,7	40
F33160236	2	53,2	16	F33160243	4	69,1	25	F33160250	6	76,7	40

STRIKER PLATE - DISTANZKAPPE - REAZIONE PER CILINDRO

Notes

Material: 16MnCr5
HRC: 60±63

STOCK

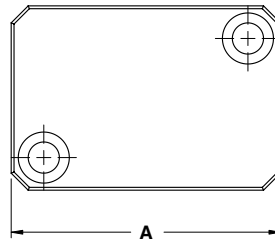
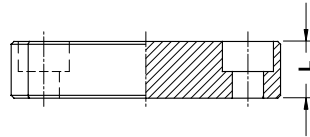
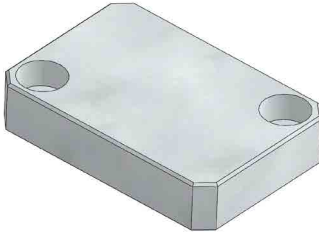

Standard Opel

	OPEL CODE	
	F33160227	

OPEL CODE	A	L	OPEL CODE	A	L	OPEL CODE	A	L	OPEL CODE	A	L	OPEL CODE	A	L
F33160226	50	20	F33160277	80	23	F33160286	95	35	F33160327	80	22	F33160336	130	20
F33160227	80	20	F33160278	80	26	F33160287	110	23	F33160328	80	24	F33160337	130	22
F33160228	95	20	F33160279	80	29	F33160288	110	26	F33160329	80	28	F33160338	130	23
F33160229	110	20	F33160280	80	32	F33160289	110	29	F33160330	95	22	F33160339	130	24
F33160272	50	23	F33160281	80	35	F33160290	110	32	F33160331	95	24	F33160340	130	26
F33160273	50	26	F33160282	95	23	F33160291	110	35	F33160332	95	28	F33160341	130	28
F33160274	50	29	F33160283	95	26	F33160324	50	22	F33160333	110	22	F33160342	130	29
F33160275	50	32	F33160284	95	29	F33160325	50	24	F33160334	110	24	F33160343	130	32
F33160276	50	35	F33160285	95	32	F33160326	50	28	F33160335	110	28	F33160344	130	35

STRIKER PLATE - DISTANZKAPPE - REAZIONE PER CILINDRO

Notes

Material: 42CrMo4

HRC: 48÷55

STOCK

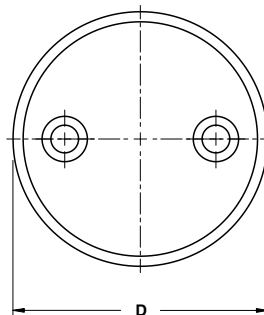
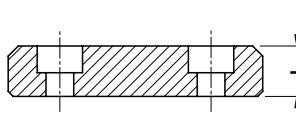
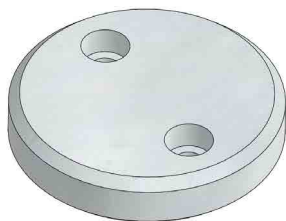

	OPEL CODE
	F33160346

OPEL CODE	D	L	OPEL CODE	D	L	OPEL CODE	D	L
F33160345	63	20	F33160354	101	20	F33160363	133	20
F33160346	63	22	F33160355	101	22	F33160364	133	22
F33160347	63	23	F33160356	101	23	F33160365	133	23
F33160348	63	24	F33160357	101	24	F33160366	133	24
F33160349	63	26	F33160358	101	26	F33160367	133	26
F33160350	63	28	F33160359	101	28	F33160368	133	28
F33160351	63	29	F33160360	101	29	F33160369	133	29
F33160352	63	32	F33160361	101	32	F33160370	133	32
F33160353	63	35	F33160362	101	35	F33160371	133	35

WASHER - SCHEIBE - RONDELLA

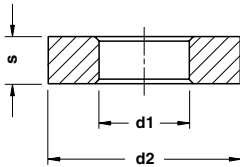

Notes

Material: CK45

STOCK

ORDER EXAMPLE	OPEL CODE		
	F33180008		
OPEL CODE	d1	d2	s
F33180007	6	16	3.5
F33180008	12	24.5	5
F33180009	16	32	6.5
F33180010	20	40	8
F33180011	24	50	10
F33180012	30	60	12

Standard Opel

LOCATING CONE - KEGELDISTANZ - CONO DI CENTRAGGIO

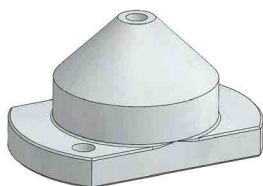

FORM A

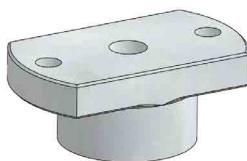

FORM B

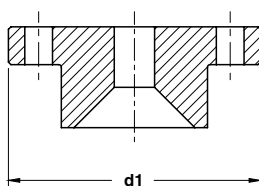
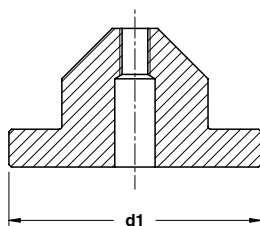

Notes

Material: 16MnCr5

HRC: 60÷62

STOCK



OPEL CODE

F33190004

OPEL CODE	d1	FORM
F33190003	100	B
F33190004	120	B
F33190037	100	A
F33190038	120	A

SPACER - DISTANZSTÜCK - DISTANZIALE

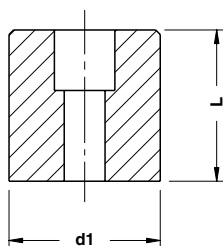

Notes

Material: CK45

STOCK



OPEL CODE

F33190006

OPEL CODE	d1	L
F33190005	50	50
F33190006	80	50
F33190025	100	50
F33190026	80	160

BOTTOMING BLOCK - ABSTANDBLOCK - DISTANZIALE

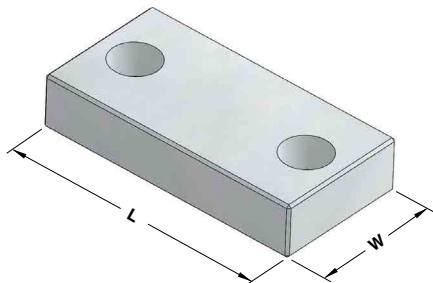

Notes

Material: CK45

STOCK

	OPEL CODE
	F33190032

OPEL CODE	L	W
F33190031	100	30
F33190032	100	40
F33190033	80	40
F33190034	100	50

Standard Opel

SPACER - DISTANZSTÜCK - DISTANZIALE

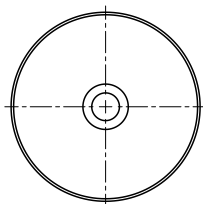
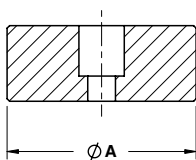
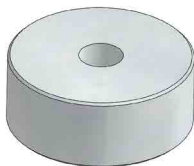

Notes

Material: CK45

STOCK

	OPEL CODE
	F33190036

OPEL CODE	A
F33190035	50
F33190036	75

KEY - PASSFEDER - CHIAVETTA

Notes

Material: CK45

STOCK

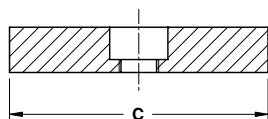
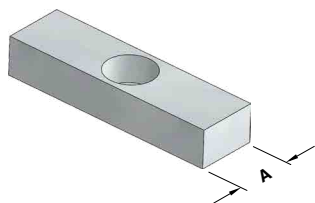

FORM A

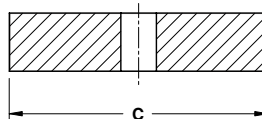
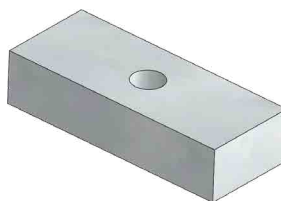

FORM B

	OPEL CODE
	F33200010

OPEL CODE	A	C	FORM	OPEL CODE	A	C	FORM	OPEL CODE	A	C	FORM
F33200009	22	50	A	F33200018	25	50	A	F33200025	32	100	B
F33200010	22	80	A	F33200019	25	80	A	F33200026	25	100	A
F33200011	22	100	A	F33200023	32	50	B	F33200033	32	100	A
F33200017	20	80	A	F33200024	32	80	B				

ROLLER CAM UNIT - ROLLENSCHIEBER - CAMMA A RULLO

Notes

For technical info see pages 860÷897

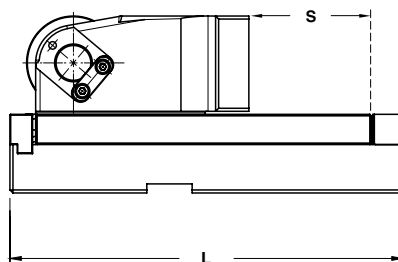
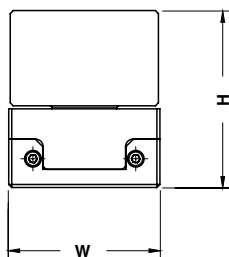
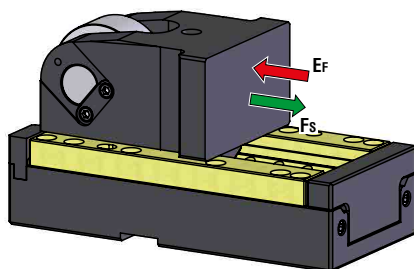

OPEL CODE
F33220333

OPEL CODE	L	H	W	Stroke (mm)	Max Work Force (kN)	Extraction Force (kN)
				S	Fs	Ef
						Gas Spring
F33220332	200	117	98	50	76	2,86
F33220333	230	117	98	80	76	2,89
F33220334	260	117	98	100	76	3,09
F33220335	200	140	118	50	162	6,5
F33220336	230	140	118	80	162	6,62
F33220337	260	140	118	100	162	7,26
F33220338	220	165	170	50	166	6,36
F33220339	250	165	170	80	166	6,43
F33220340	270	165	170	100	166	6,46
F33220341	250	205	240	50	258	9,29
F33220342	280	205	240	80	258	9,36
F33220343	300	205	240	100	258	9,38

GAGE - EINWEISER - RIFERIMENTO

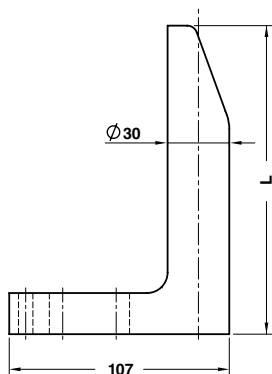
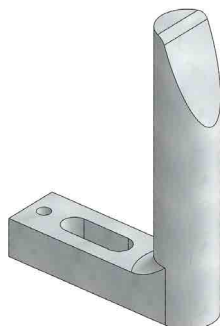

Notes

Material: CK60

STOCK



OPEL CODE

F33260005

OPEL CODE	L
F33260004	65
F33260005	90
F33260006	120
F33260007	150
F33260008	180
F33260009	250
F33260396	300
F33260397	350

ACCELERATION CAM - SCHIEBERVORBESCHLEUNIGUNG - CAMMA DI ACCELERAZIONE

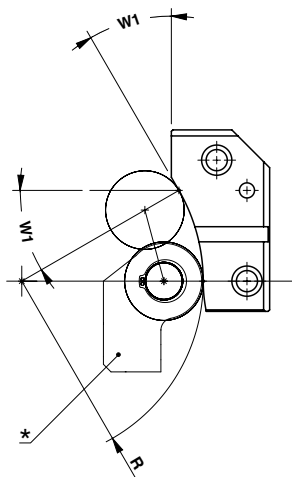
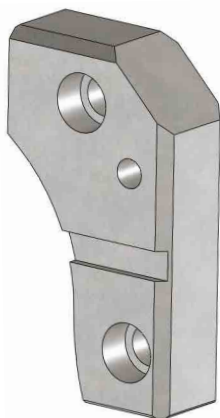

Notes

Materials: 90MnCrV8 - HRC 60÷62



OPEL CODE

F33260015

OPEL CODE	R	W1
F33260014	90	40°
F33260015	90	37.5°
F33260016	100	37.5°
F33260017	100	35°
F33260020	75	42.5°
F33260021	75	45°
F33260022	75	47.5°
F33260023	65	50°
F33260024	65	52.5°

* Cam roller
Rollenbock
Supporto con rullo

CAM ROLLER - ROLLENBOCK - SUPPORTO CON RULLO

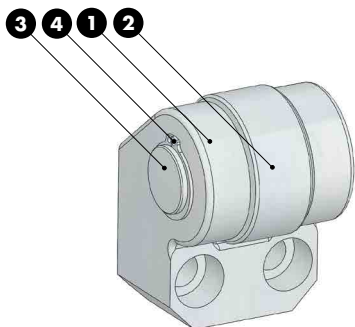

Notes

- 1 **Material:** 42CrMo4
- 2 NUTR 25-52
- 3 **Material:** 16MnCr5
HRC: 60±62
- 4 E25 DIN 471

STOCK



OPEL CODE

F33260032

OPEL CODE

F33260032

Standard Opel

FRONT GAGE - EINLAUFANSCHLAG - PORTASENSORE

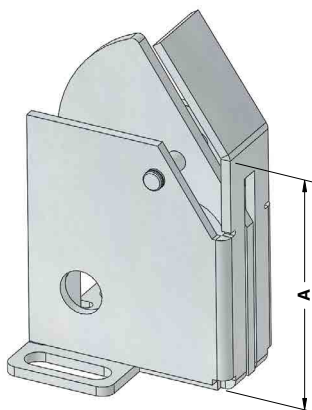

Notes

Material: Si37

STOCK



OPEL CODE

F33260204

OPEL CODE

A

F33260203

75

F33260204

100

F33260205

150

SLIDE STOP BLOCK - SCHIEBERANSCHLAG - ARRESTO SLITTA

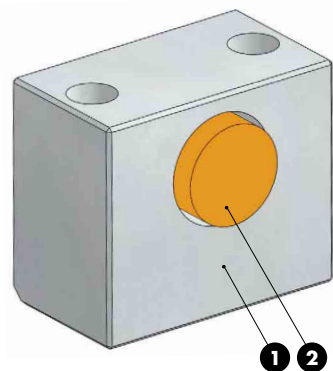

Notes

- 1 Material:** CK45
- 2 Material:** Elastomer 90 SH

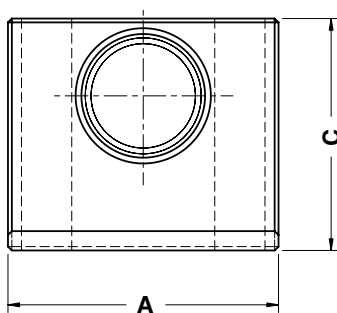
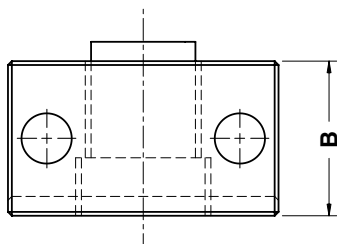

	OPEL CODE
	F33260264

OPEL CODE	A	B	C
F33260223	80	80	70
F33260264	80	40	70
F33260342	70	40	60

STAMP RACK PILLAR - MARKIERSTEMPELKONSOLE - COLONNA PORTATIMBRI

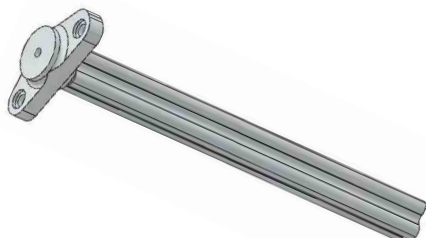

Notes

Material: CK45

STOCK



OPEL CODE

F33290002

OPEL CODE

F33290002

Standard Opel

COUNTER-PRESSURE PLATE - GEGENDRUCKPLATTE - PIASTRINA DI REAZIONE

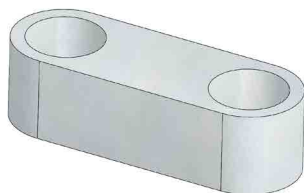

Notes

Material: Si37

STOCK



OPEL CODE

F33290041

OPEL CODE

F33290041

STAMP - BUCHSTABENSTEMPEL - PUNZONE MARCHIO

Notes

Material: 90MnCrV8
HRC: 60÷64

STOCK

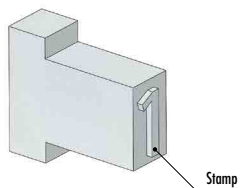

	OPEL CODE
	F33290044

OPEL CODE	Stamp	OPEL CODE	Stamp	OPEL CODE	Stamp	OPEL CODE	Stamp
F33290043	0	F33290052	9	F33290150	J	F33290159	U
F33290044	1	F33290142	A	F33290151	K	F33290160	V
F33290045	2	F33290143	B	F33290152	L	F33290161	W
F33290046	3	F33290144	C	F33290153	M	F33290162	X
F33290047	4	F33290145	D	F33290154	N	F33290163	Y
F33290048	5	F33290146	E	F33290155	P	F33290164	Z
F33290049	6	F33290147	F	F33290156	R		
F33290050	7	F33290148	G	F33290157	S		
F33290051	8	F33290149	H	F33290158	T		

STAMP - BUCHSTABENSTEMPEL - MARCHIO

Notes

Material: 90MnCrV8
HRC: 60÷64

STOCK

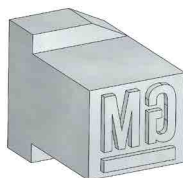

	OPEL CODE
	F33290063
OPEL CODE	
F33290063	

VISUAL LOCATOR PUNCH - ENDKONTROLLSTEMPEL - PUNZONE DI VISUALIZZAZIONE

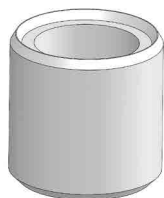

Notes
Material: X155CrVMo121KU HRC: 60÷64

STOCK

<small>ORDER EXAMPLE</small> 	OPEL CODE
	F33290068

OPEL CODE
F33290068

Standard Opel

AIR COUPLING BRACKET - LUFTANSCHLUSSBLOCK - SUPPORTO INNESTI RAPIDI

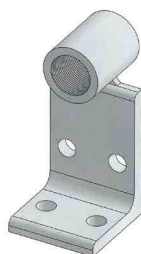

Notes	
Material: Si37	
STOCK	
	OPEL CODE
	F33910001
OPEL CODE	
F33910001	

AIR COUPLING BRACKET - LUFTANSCHLUSSBLOCK - SUPPORTO INNESTI RAPIDI

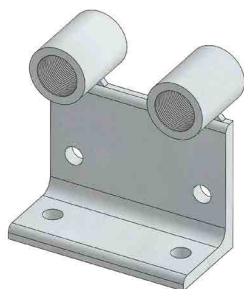

Notes	
Material: Si37	
STOCK	
	OPEL CODE
	F33910002
OPEL CODE	
F33910002	

AIR COUPLING BRACKET - LUFTANSCHLUSSBLOCK - SUPPORTO INNESTI RAPIDI

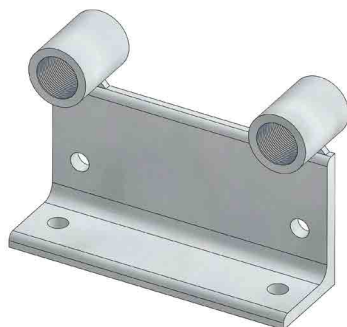

Notes	
Material: Si37	
STOCK	
	OPEL CODE
	F33910003
OPEL CODE	
F33910003	

RETAINER FOR STAMPS - HALTEPLATTE - PORTATIMBRI

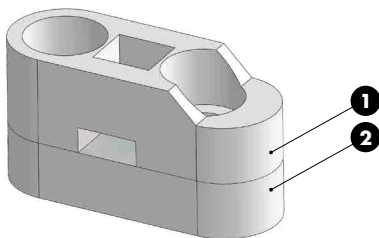

Notes	
1	F33290065 - Material: St37
2	F33290066 - Material: CK45



	OPEL CODE
	F33910043
OPEL CODE	
F33910043	

Standard Opel

RETAINER FOR STAMPS - HALTEPLATTE - PORTATIMBRI

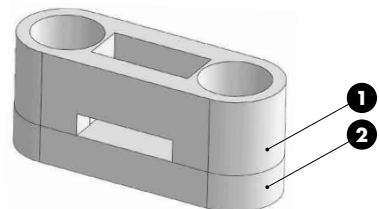

Notes	
1	F33290039 - Material: CK45
2	F33290040 - Material: CK45



	OPEL CODE
	F33910044
OPEL CODE	
F33910044	

BUSH FOR LIFTING PIN - BUCHSE FÜR TRAGBOLZEN - BOCCOLA PER PERNO DI SOLLEVAMENTO

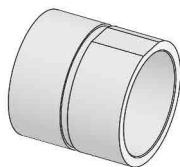

FORM A

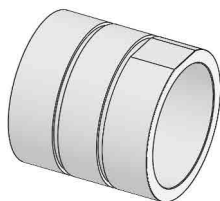
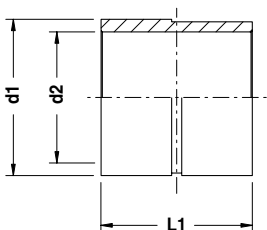

FORM B

Notes

Material: Si35

STOCK

	OPEL CODE
	F33910111

OPEL CODE	d1	d2	L1	FORM
F33910110	44	34	40	A
F33910111	52	42	50	A
F33910112	62	52	60	A
F33910113	75	65	80	A
F33910114	75	65	75	A
F33910115	100	82	100	B

SENSOR MOUNTING BRACKET - SENSORHALTERUNGEN - STAFFA PER SENSORE

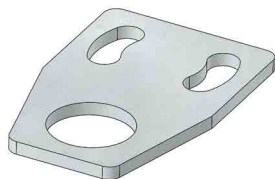

J06910069

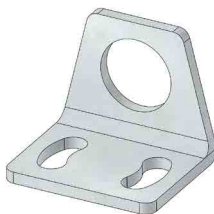

J06910070

Notes

Material: Si37

STOCK

	OPEL CODE
	J06910070

OPEL CODE
J06910069
J06910070

SHOCK ABSORBER - HALTELEMENT - AMMORTIZZATORE

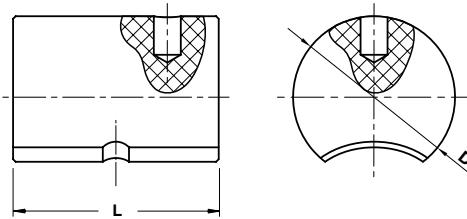
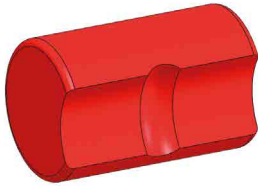

Notes

Material: Polyurethane 92 SH

STOCK

	OPEL CODE		
	M16045183		
	OPEL CODE	D	L
	M16045182	40	60
	M16045183	50	80
	M16045184	63	80

Standard Opel

WASHER - SCHEIBE - RONDELLA

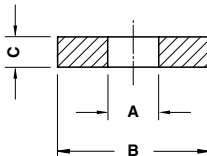
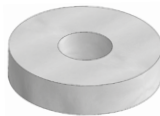

Notes

Material: CK45

STOCK

	OPEL CODE			
	M36600071			
	OPEL CODE	A	B	C
	M36600070	8,4	21	4
	M36600071	10,5	25	4
	M36600072	13	30	6
	M36600073	17	40	6

