











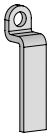

Die Components
Normalien
Componenti

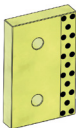
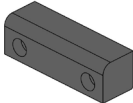
Mercedes-Benz

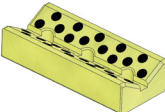
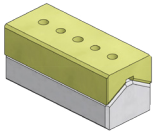
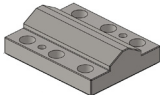
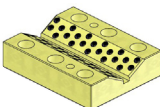
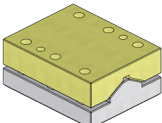
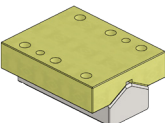
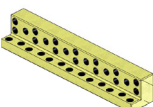
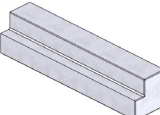

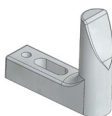
OMCR[®]
STANDARD DIE COMPONENTS



APPROVED BY MERCEDES-BENZ - FREIGEgeben VON MERCEDES-BENZ - APPROVATO DA MERCEDES-BENZ

B8 0110 100 008 805	B8 0162 410 008 801	B8 0301 231 108 801	B8 0460 219 008 801	B8 0460 231 009 003
				
Washer Scheibe Rondella 410	Bracket for lifting pin Bügel für Tragbolzen Staffa per perno di sollevamento 410	Bush for lifting pin Buchse für Tragbolzen Boccola per perno di sollevamento 411	Wear plate Gleitplatte Piastra guida 412	Wear plate Gleitplatte Piastra guida 413
B8 0460 850 000 101	B8 0461 110 000 101	B8 0461 131 000 101	B8 0461 191 000 101	B8 0461 210 000 101
				
Draw punch protector Ziehstempelschutz Tassello di protezione 414	"V" driver Prismenführung Guida a "V" 414	"V" driver Prismenführung Guida a "V" 415	"V" driver Prismenführung Guida a "V" 415	"V" driver Prismenführung Guida a "V" 416
B8 0461 213 000 101	B8 0461 291 000 101	B8 0461 391 000 101	B8 0466 100 000 101	B8 0466 200 000 101
				
"V" driver Prismenführung Guida a "V" 416	"V" driver Prismenführung Guida a "V" 417	"V" driver Prismenführung Guida a "V" 417	Angular guide Führungswinkel Guida angolare 418	Angular guide Führungswinkel Guida angolare 418
B8 0541 000 009 001	B8 0541 000 009 005	B8 0602 321 008 801	B8 1013 110 008 802	B8 1240 300 009 001
				
Gage Einweiser Riferimento 419	Gage Einweiser Riferimento 419	Locating pin Zentrierbolzen Perno di centraggio 420	Collar screw Schulter Passschraube Vite con colletto 421	Lifting bracket VDI 3366 Tragzapfen VDI 3366 Staffa di sollevamento VDI 3366 422

APPROVED BY MERCEDES-BENZ - FREIGEgeben VON MERCEDES-BENZ - APPROVATO DA MERCEDES-BENZ

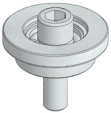
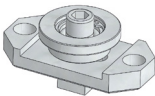
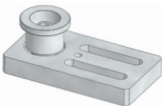





B8 2002 231 009 001	B8 2002 621 008 802	B8 7007 000 008 808	B8 7007 000 008 809	B8 7007 000 008 810
				
<p>Lifting Pin Tragbolzen mit Fallringsicherung Perno di sollevamento</p>	<p>Pad retainer pin Steckbolzen Perno di arresto</p>	<p>Coil guide roller Führungsrolle Guida nastro</p>	<p>Coil guide roller Führungsrolle Guida nastro</p>	<p>Coil guide roller Führungsrolle Guida nastro</p>
423	424	424	425	425

Standard
Mercedes-Benz

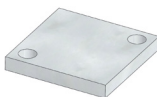
SIMILAR TO MERCEDES-BENZ - ÄHNLICH MERCEDES-BENZ - SIMILE A MERCEDES-BENZ

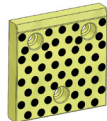
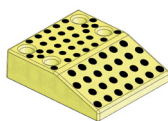
<p>A30</p>  <p>Elastomer Washer Daempfungsscheibe Rondella in elastomero</p> <p>426</p>	<p>A31</p>  <p>Washer Scheibe Rondella</p> <p>426</p>	<p>A32</p>  <p>Key Passfeder Chiavetta</p> <p>427</p>	<p>A33</p>  <p>Guide post Führungssäule Colonna guida</p> <p>428</p>	<p>A34</p>  <p>Guide Post Führungssäule Colonna Guida</p> <p>429</p>
<p>A44</p>  <p>Locating block Fangbacke Tassello di centraggio</p> <p>431</p>	<p>A45</p>  <p>Gage for sensor Einweiser für Teillagekontrolle Riferimento per sensore</p> <p>431</p>	<p>A47</p>  <p>Spacer Distanzscheibe Distanziale</p> <p>432</p>	<p>A49</p>  <p>Stop Block Abstandsblock Distanziale</p> <p>432</p>	<p>A50</p>  <p>Locating pin Zentrierbolzen Centraggio</p> <p>433</p>
<p>A51</p>  <p>Spring pin Aufnahmebolzen Perno per molla</p> <p>433</p>	<p>A54</p>  <p>Spacer Abstimmerschraube Distanziale</p> <p>434</p>	<p>A55</p>  <p>Post ring Sprengring Anello per colonna</p> <p>434</p>	<p>A56</p>  <p>Elastomer spring Elastomerfeder Molla in elastomero</p> <p>435</p>	<p>A57</p>  <p>Retainer bolt Haltebolzen Tirante</p> <p>435</p>
<p>A58</p>  <p>Upper air cushion pin Oberluftbolzen Candela superiore</p> <p>430</p>	<p>A59</p>  <p>Cam roller Rollenbock Supporto con rullo</p> <p>436</p>	<p>C10.18</p>  <p>Gage Einweiser Riferimento</p> <p>437</p>	<p>C11.09</p>  <p>Locating Cone Kegelaufsatz Cono Di Centraggio</p> <p>437</p>	<p>C11.11</p>  <p>Locating cone Zentrierzapfen Cono di centraggio</p> <p>438</p>

SIMILAR TO MERCEDES-BENZ - ÄHNLICH MERCEDES-BENZ - SIMILE A MERCEDES-BENZ

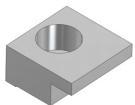
C12.24	E40.06	E40.12	E44.12	E44.13
				
Backing plate Distanzkappe Reazione per cilindro	Wear plate Gleitplatte Piastra guida	Wear plate Gleitplatte Piastra guida	Cam dwell Überlaufkeile Cuneo	Cam dwell Überlaufkeile Cuneo
438	439	440	441	442
E45.10	E45.10W	E46.10	E47.10	
				
Guide Post Führungssäule Colonna Guida	Guide Post Führungssäule Colonna Guida	Bush self-lubricating DIN 9834 Führungsbuchse DIN 9834 Boccola autolubrificante DIN 9834	Toe clamp Haltestück Ritegno	
443	444	445	445	

Standard
Mercedes-Benz

WASHER - SCHEIBE - RONDELLA

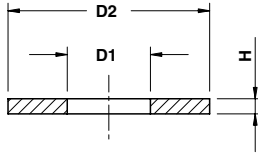
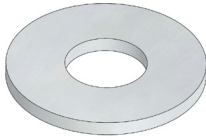

Notes

Material: CK45

STOCK



MERCEDES-BENZ CODE
B8 0110 0332957

MERCEDES-BENZ CODE	D1	D2	H	MERCEDES-BENZ CODE	D1	D2	H	MERCEDES-BENZ CODE	D1	D2	H
B8 0110 0332956	14	40	6	B8 0110 0332962	17	80	6	B8 0110 0377008	39	100	8
B8 0110 0332957	14	50	6	B8 0110 0332963	17	80	12	B8 0110 0377011	39	110	8
B8 0110 0332958	14	50	8	B8 0110 0332964	21	50	6				
B8 0110 0332959	17	36	4	B8 0110 0332965	21	100	8				
B8 0110 0332960	17	60	6	B8 0110 0332966	21	100	14				
B8 0110 0332961	17	60	10	B8 0110 0332967	21	120	10				

BRACKET FOR LIFTING PIN - BÜGEL FÜR TRAGBOLZEN - STAFFA PER PERNO DI SOLLEVAMENTO

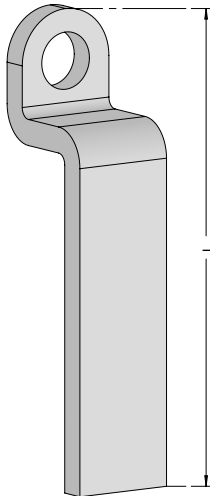

STOCK

Notes

Material: Si37

Application example

B8 0162 410 008 801

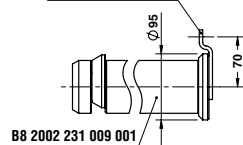

MERCEDES-BENZ CODE
B8 0162 0530492

MERCEDES-BENZ CODE	L
B8 0162 1104475	90

BUSH FOR LIFTING PIN - BUCHSE FÜR TRAGBOLZEN - BOCCOLA PER PERNO DI SOLLEVAMENTO

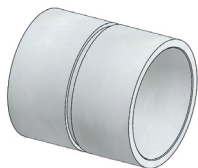

FORM A

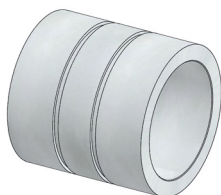
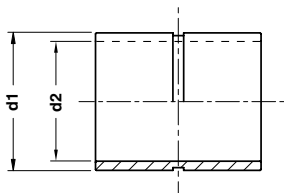

FORM B

Notes

Material: Si35

STOCK

	MERCEDES-BENZ CODE		
	B8 0301 0274833		

MERCEDES-BENZ CODE	d1	d2	FORM
B8 0301 0274828	44	34	A
B8 0301 0274833	52	42	A
B8 0301 0274835	62	52	A
B8 0301 0274836	75	65	A
B8 0301 0274838	100	78	B
B8 0301 0274842	105	78	B

Standard Mercedes-Benz

WEAR PLATE STEEL - GLEITPLATTE STAHL - PIASTRA GUIDA IN ACCIAIO

Notes

Material: X155CrMo121KU

HRC: 60±62

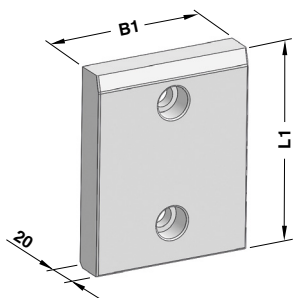

FORM A

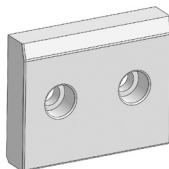

FORM B

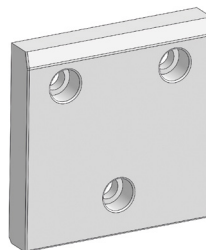

FORM C

	MERCEDES-BENZ CODE
	B8 0460 0332878

MERCEDES-BENZ CODE	B1	L1	FORM	MERCEDES-BENZ CODE	B1	L1	FORM
B8 0460 0332860	60	80	A	B8 0460 0332875	110	160	A
B8 0460 0332861	60	100	A	B8 0460 0332876	110	200	A
B8 0460 0332862	60	125	A	B8 0460 0332877	135	50	B
B8 0460 0332863	60	160	A	B8 0460 0332878	135	80	B
B8 0460 0332864	60	200	A	B8 0460 0332879	135	100	C
B8 0460 0332865	90	50	B	B8 0460 0332880	135	125	C
B8 0460 0332866	90	80	A	B8 0460 0332881	135	160	C
B8 0460 0332867	90	100	A	B8 0460 0332882	135	200	C
B8 0460 0332868	90	125	A	B8 0460 0332883	170	50	B
B8 0460 0332869	90	160	A	B8 0460 0332884	170	80	B
B8 0460 0332870	90	200	A	B8 0460 0332885	170	100	C
B8 0460 0332871	110	50	B	B8 0460 0332886	170	125	C
B8 0460 0332872	110	80	B	B8 0460 0332887	170	160	C
B8 0460 0332873	110	100	A	B8 0460 0332888	170	200	C
B8 0460 0332874	110	125	A				

**WEAR PLATE SELF-LUBRICATING
GLEITPLATTE BRONZE MIT FESTSCHMIERSTOFF
PIASTRA GUIDA AUTOLUBRIFICANTE**

Notes

Material: Bronze + Graphite
HB > 190

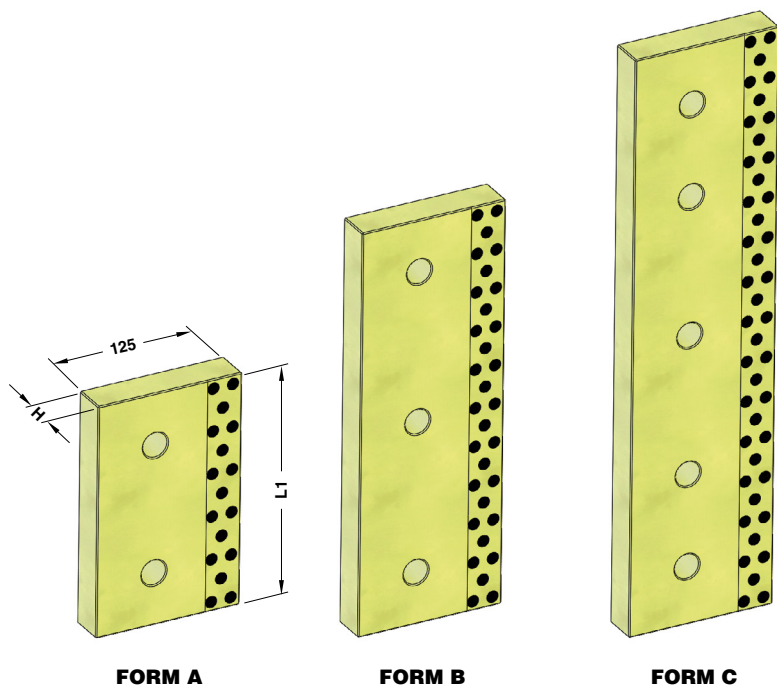

Standard
Mercedes-Benz

	MERCEDES-BENZ CODE
	B8 0460 0528244

MERCEDES-BENZ CODE	H	L1	FORM	MERCEDES-BENZ CODE	H	L1	FORM	MERCEDES-BENZ CODE	H	L1	FORM
B8 0460 0528243	25	160	A	B8 0460 0528246	25	400	C	B8 0460 0528249	30	250	B
B8 0460 0528244	25	200	A	B8 0460 0528247	30	160	A	B8 0460 0528250	30	400	C
B8 0460 0528245	25	250	B	B8 0460 0528248	30	200	B				

**DRAW PUNCH PROTECTOR
ZIEHSTEMPELSCHUTZ
TASSELLO PROTEZIONE PUNZONE IMBUTITURA**

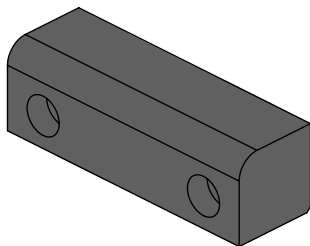

Notes

Material: POLYAMIDE PA 6 E

STOCK



MERCEDES-BENZ CODE

B8 0460 0331968

MERCEDES-BENZ CODE

B8 0460 0331968

"V" DRIVER STEEL - PRISMENFÜHRUNG STAHL - GUIDA A "V" IN ACCIAIO

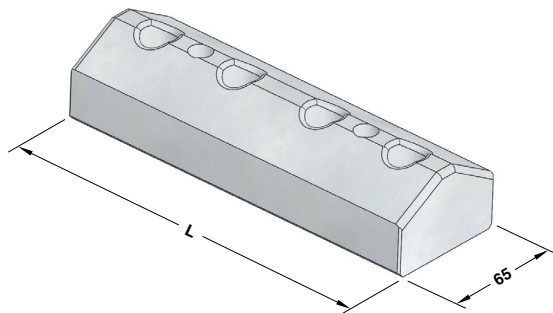

Notes

Material: CK45

HRC: 58÷60

STOCK



MERCEDES-BENZ CODE

B8 0461 0330554

MERCEDES-BENZ CODE	L
B8 0461 0330553	150
B8 0461 0330554	200
B8 0461 0330555	250
B8 0461 0330556	300
B8 0461 1490340	350
B8 0461 1490342	400

**"V" DRIVER SELF-LUBRICATING
PRISMENFÜHRUNG BRONZE MIT FESTSCHMIERSTOFF
GUIDA A "V" AUTOLUBRIFICANTE**

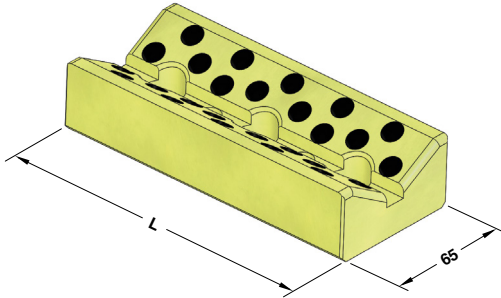

Notes
Material: Bronze + Graphite
HB > 190

STOCK

	MERCEDES-BENZ CODE	
	B8 0461 0330550	
	MERCEDES-BENZ CODE	L
	B8 0461 0330549	150
	B8 0461 0330550	200
	B8 0461 0330551	250
	B8 0461 0330552	300
	B8 0461 1490337	350
	B8 0461 1490338	400

Standard
Mercedes-Benz

"V" DRIVER STEEL - PRISMENFÜHRUNGSGRUPPE - SET DI GUIDE A "V"

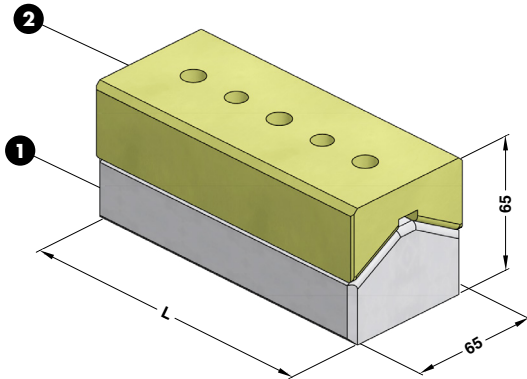

Notes
1 Material: CK45
HRC: 55÷60
2 Material: Bronze + Graphite
HB > 190

STOCK

	MERCEDES-BENZ CODE	L=100
	B8 0461 0330565	100
	MERCEDES-BENZ CODE	L
	B8 0461 0330565	150
	B8 0461 0330566	200
	B8 0461 0330567	250
	B8 0461 0330568	300

"V" DRIVER STEEL - PRISMENFÜHRUNG STAHL - GUIDA A "V" IN ACCIAIO

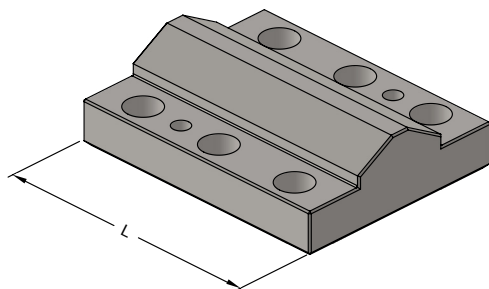

Notes

Material: CK45
HRC: 55÷60

STOCK



MERCEDES-BENZ CODE
B8 0461 0330562

MERCEDES-BENZ CODE	L
B8 0461 0330561	150
B8 0461 0330562	200
B8 0461 0330563	250
B8 0461 0330564	300

**"V" DRIVER SELF-LUBRICATING
 PRISMENFÜHRUNG BRONZE MIT FESTSCHMIERSTOFF
 GUIDA A "V" AUTOLUBRIFICANTE**

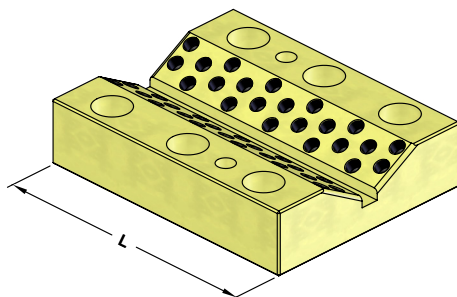

Notes

Material: Bronze + Graphite
HB > 190

STOCK



MERCEDES-BENZ CODE
B8 0461 0330558

MERCEDES-BENZ CODE	L
B8 0461 0330557	150
B8 0461 0330558	200
B8 0461 0330559	250
B8 0461 0330560	300

"V" DRIVER SET - PRISMENFÜHRUNGSGRUPPE - SET DI GUIDE A "V"

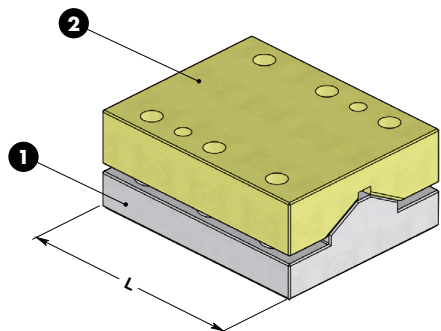

Notes

- 1** Material: CK45
HRC: 55÷60
- 2** Material: Bronze + Graphite
HB > 190



	MERCEDES-BENZ CODE
	B8 0461 0330569
MERCEDES-BENZ CODE	L
B8 0461 0330569	150
B8 0461 0330570	200
B8 0461 0330571	250
B8 0461 0330572	300

Standard Mercedes-Benz

"V" DRIVER SET - PRISMENFÜHRUNGSGRUPPE - SET DI GUIDE A "V"

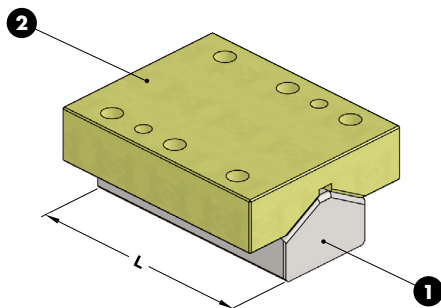

Notes

- 1** Material: CK45
HRC: 55÷60
- 2** Material: Bronze + Graphite
HB > 190



	MERCEDES-BENZ CODE
	B8 0461 0331829
MERCEDES-BENZ CODE	L
B8 0461 0331829	150
B8 0461 0331830	200
B8 0461 0331831	250
B8 0461 0331832	300

**ANGULAR GUIDE SELF-LUBRICATING
FÜHRUNGSWINKEL BRONZE MIT FESTSCHMIERSTOFF
GUIDA ANGOLARE AUTOLUBRIFICANTE**

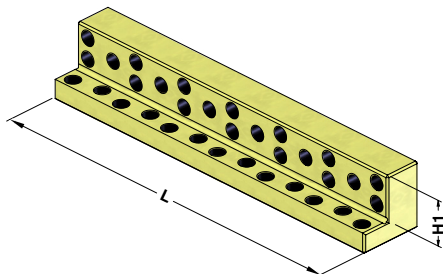

Notes

Material: Bronze + Graphite
HRC: >190

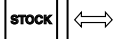

	MERCEDES-BENZ CODE	L=500
	B8 0466 1568869	L500

MERCEDES-BENZ CODE	L	H1
B8 0466 1568867	Length to 200	24
B8 0466 1568868	Length to 400	24
B8 0466 1568869	Length to 605	24
B8 0466 1568870	Length to 200	34
B8 0466 1568871	Length to 400	34
B8 0466 1568872	Length to 605	34

**ANGULAR GUIDE STEEL
FÜHRUNGSWINKEL STAHL
GUIDA ANGOLARE IN ACCIAIO**

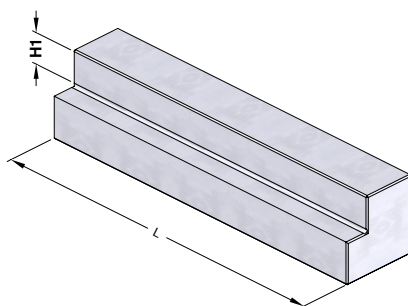

Notes

Material: CK45
HRC: 48÷45



	MERCEDES-BENZ CODE	L=200
	B8 0466 1568877	L200

MERCEDES-BENZ CODE	L	H1	MERCEDES-BENZ CODE	L	H1	MERCEDES-BENZ CODE	L	H1
B8 0466 1568873	Length to 100	15	B8 0466 1568879	Length to 100	25	B8 0466 1568885	Length to 100	35
B8 0466 1568874	Length to 250	15	B8 0466 1568880	Length to 250	25	B8 0466 1568886	Length to 250	35
B8 0466 1568875	Length to 400	15	B8 0466 1568881	Length to 400	25	B8 0466 1568887	Length to 400	35
B8 0466 1568876	Length to 100	20	B8 0466 1568882	Length to 100	30	B8 0466 1568888	Length to 100	44
B8 0466 1568877	Length to 250	20	B8 0466 1568883	Length to 250	30	B8 0466 1568889	Length to 250	44
B8 0466 1568878	Length to 400	20	B8 0466 1568884	Length to 400	30	B8 0466 1568890	Length to 400	44

GAGE - EINWEISER - RIFERIMENTO

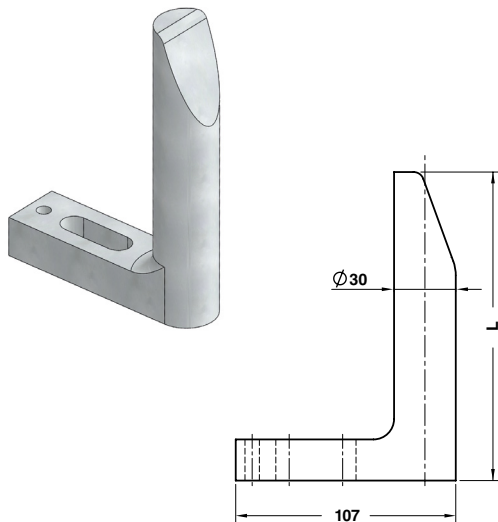

Notes

Material: CK60

STOCK



	MERCEDES-BENZ CODE
	B8 0541 0332635
MERCEDES-BENZ CODE	L
B8 0541 0332634	65
B8 0541 0332635	90
B8 0541 0332636	120
B8 0541 0332637	150
B8 0541 0332638	180
B8 0541 0332641	250

Standard
Mercedes-Benz

GAGE HARDENED - EINWEISER GEHÄRTET - RIFERIMENTO INDURITO

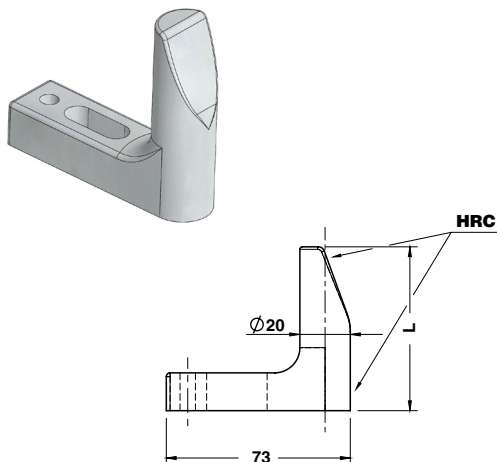

Notes

Material: CK60 - **HRC:** 58÷60

STOCK



	MERCEDES-BENZ CODE
	B8 0541 0093840
MERCEDES-BENZ CODE	L
B8 0541 0093839	65
B8 0541 0093840	90

LOCATING PIN - ZENTRIERBOLZEN - PERNO DI CENTRAGGIO

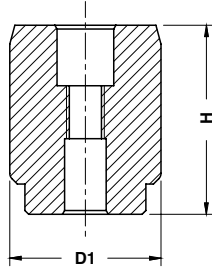

Notes

Material: 16MnCr5 - **HRC:** 60÷62

STOCK

	MERCEDES-BENZ CODE
	B8 0602 0333315

MERCEDES-BENZ CODE	D1	H
B8 0602 1061335	11	70
B8 0602 0333314	22	50
B8 0602 0333315	25	50
B8 0602 0333316	32	50
B8 0602 1061342	15	70
B8 0602 0333317	40	50
B8 0602 0333318	50	50

COLLAR SCREW - SCHULTER PASSSCHRAUBE - VITE CON COLLETO

Notes
DIN 898 cl. 12.9

STOCK

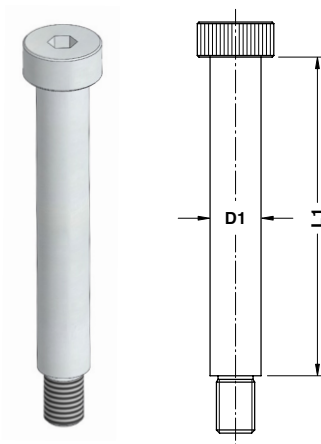

Standard
Mercedes-Benz

	MERCEDES-BENZ CODE
	B8 1013 0789539

MERCEDES-BENZ CODE	D1	L1	MERCEDES-BENZ CODE	D1	L1	MERCEDES-BENZ CODE	D1	L1
B8 1013 0528837	16	70	B8 1013 0528845	20	60	B8 1013 0789540	16	35
B8 1013 0528838	16	80	B8 1013 0528846	20	70	B8 1013 0789542	16	40
B8 1013 0528839	16	90	B8 1013 0528847	20	80	B8 1013 0789543	16	45
B8 1013 0528840	16	100	B8 1013 0528848	20	90	B8 1013 1018326	8	16
B8 1013 0528841	16	120	B8 1013 0528849	20	100	B8 1013 1043713	8	50
B8 1013 0528842	16	60	B8 1013 0528850	20	120	B8 1013 1060773	12	30
B8 1013 0528843	16	50	B8 1013 0571679	16	30			
B8 1013 0528844	20	50	B8 1013 0789539	16	25			

LIFTING BRACKET VDI 3366 - TRAGZAPFEN VDI 3366 - STAFFA DI SOLLEVAMENTO VDI 3366

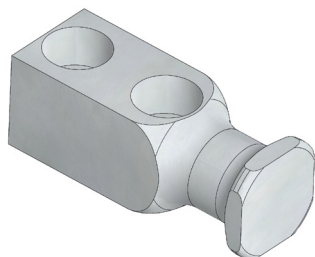

FORM A

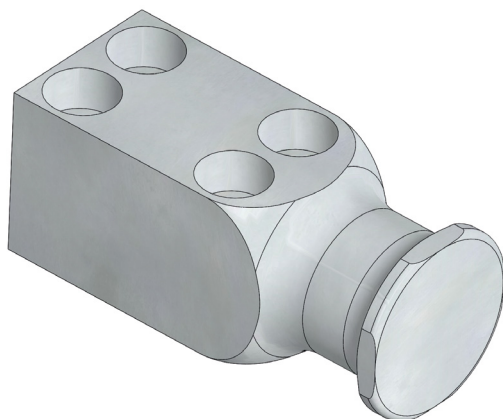

FORM B

Notes

Material: CK45 - 700÷800 N/mm²
Screws not included





Respect the max load
Maximale Nutzlast beachten
Rispettare il carico Max

WARNING - ACHTUNG - ATTENZIONE:
For safety reason, please consider always that the weight of the die has to be supported by just 2 lifting brackets.

Aus Sicherheitsgründen stets berücksichtigen, dass zwei Tragzapfens das gesamte Werkzeuggewicht tragen müssen.

Per ragioni di sicurezza, considerare sempre che il peso dello stampo deve essere sopportato da 2 sole staffe.

	MERCEDES-BENZ CODE
	B8 1240 0333079

MERCEDES-BENZ CODE	Max load (kg)	Max die weight (kg)	FORM	MERCEDES-BENZ CODE	Max load (kg)	Max die weight (kg)	FORM
B8 1240 0333078	320	640	A	B8 1240 0333083	5000	10000	A
B8 1240 0333079	630	1260	A	B8 1240 0333084	8000	16000	B
B8 1240 0333080	1250	2500	A	B8 1240 0333085	12500	25000	B
B8 1240 0333081	2000	4000	A	B8 1240 0333086	20000	40000	B
B8 1240 0333082	3200	6400	A				

LIFTING PIN - TRAGBOLZEN MIT FALLRINGSICHERUNG - PERNO DI SOLLEVAMENTO

Notes

Material: 42CrMo4 + QT



Respect the max load
 Maximale Nutzlast beachten
 Rispettare il carico Max

WARNING - ACHTUNG - ATTENZIONE:

For safety reason, please consider always that the weight of the die has to be supported by just 2 lifting pins.

Aus Sicherheitsgründen stets berücksichtigen, dass zwei Tragbolzen das gesamte Werkzeuggewicht tragen müssen.

Per ragioni di sicurezza, considerare sempre che il peso dello stampo deve essere sopportato da 2 soli perni.

Standard Mercedes-Benz

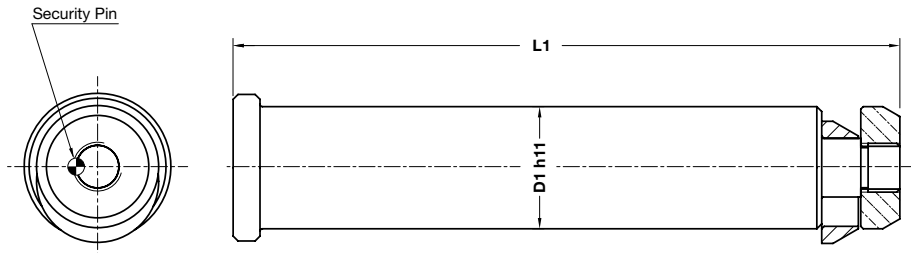
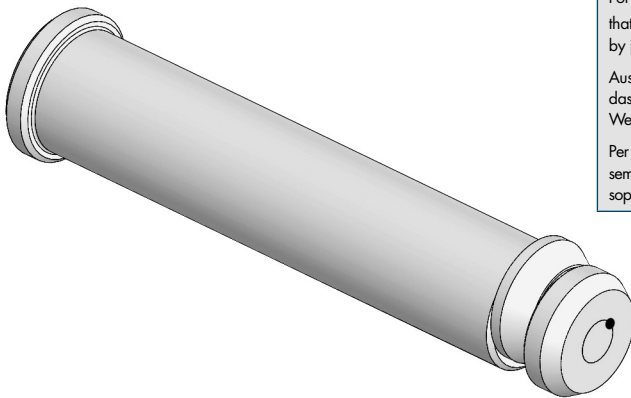

MERCEDES-BENZ CODE

B8 2002 0370694

MERCEDES-BENZ CODE	Max load (kg)	Max die weight (kg)	L1	D1
B8 2002 0370693	3200	6400	175	32
B8 2002 0370694	5000	10000	225	40
B8 2002 0537341	8000	16000	273	50
B8 2002 0537342	12500	25000	347	63
B8 2002 0537343	31500	63000	422	76

PAD RETAINER PIN - STECKBOLZEN - PERNO DI ARRESTO

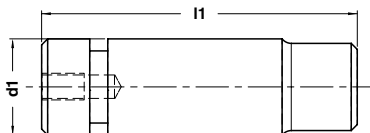
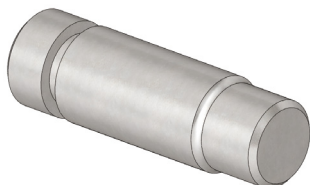

Notes

Material: CK45 - 800÷1000 N/mm²

STOCK

ORDER EXAMPLE 	MERCEDES-BENZ CODE	
	B8 2002 0333932	
MERCEDES-BENZ CODE	d1	l1
B8 2002 0333400	32	122
B8 2002 0332932	40	139
B8 2002 0332933	50	167

COIL GUIDE ROLLER - FÜHRUNGSRÖLLE - GUIDA NASTRO

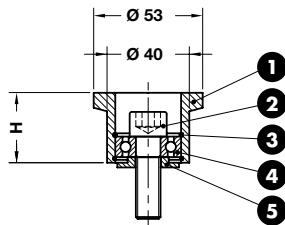
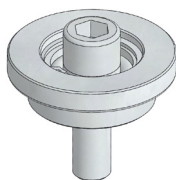

Notes

- 1** **Material:** 16MnCr5 - **HRC:** 55÷58
- 2** M12x40 DIN 472
- 3** I32 DIN 472
- 4** 6201 2Z VA DIN 625
- 5** **Material:** CK45

STOCK



ORDER EXAMPLE 	MERCEDES-BENZ CODE	
	B8 7007 0332935	
MERCEDES-BENZ CODE	H	
B8 7007 0332934	17	
B8 7007 0332935	34	
B8 7007 0530090	80	

COIL GUIDE ROLLER - FÜHRUNGSROLLE - GUIDA NASTRO

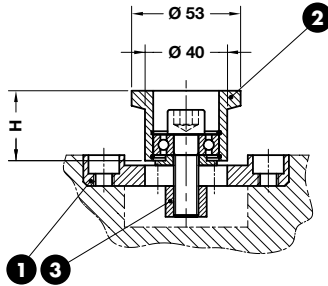
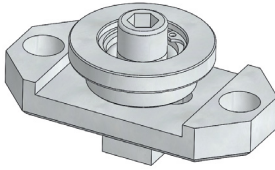

Notes

- 1 Material:** St37
B8 7007 0332934
- 2** B8 7007 0332935
B8 7007 0530090
- 3 Material:** CK45



ORDER EXAMPLE	MERCEDES-BENZ CODE
	B8 7007 0332632
MERCEDES-BENZ CODE	H
B8 7007 0332631	17
B8 7007 0332632	34
B8 7007 0557701	80

COIL GUIDE ROLLER - FÜHRUNGSROLLE - GUIDA NASTRO

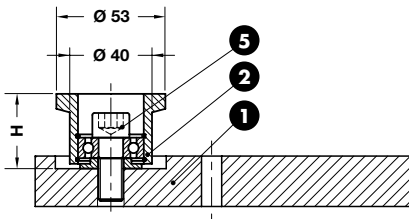
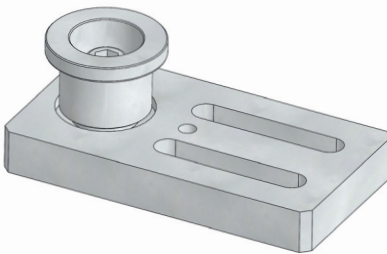

Notes

- 1 Material:** St37
B8 7007 0332935
B8 7007 0530090
- 2**
- 5** M12x25 DIN 472



ORDER EXAMPLE	MERCEDES-BENZ CODE
	B8 7007 0530089
MERCEDES-BENZ CODE	H
B8 7007 0530088	34
B8 7007 0530089	80

ELASTOMER WASHER - DAEMPfungSSCHEIBE - RONDELLA IN ELASTOMERO

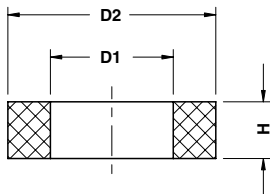
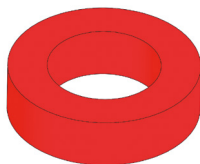

Notes

Material: Elastomer 92 SH
 Only for replacement
 Nur für Reparatur
 Solo per riparazione

STOCK

ORDER EXAMPLE	OMCR CODE
	A30.021.047

OMCR CODE	SIMILAR TO	D1	D2	H
A30.017.034	B8 0110 0332827	17	34	8
A30.021.047	B8 0110 0332828	21	47	8
A30.032.055	B8 0110 0332829	32,5	55	15
A30.038.063	B8 0110 0373385	38,5	63	15

WASHER - SCHEIBE - RONDELLA



Notes

Material: CK45

STOCK

ORDER EXAMPLE	OMCR CODE
	A31.039.068

OMCR CODE	SIMILAR TO
A31.039.068	B8 0110 0373388

KEY - PASSFEDER - CHIAVETTA

STOCK

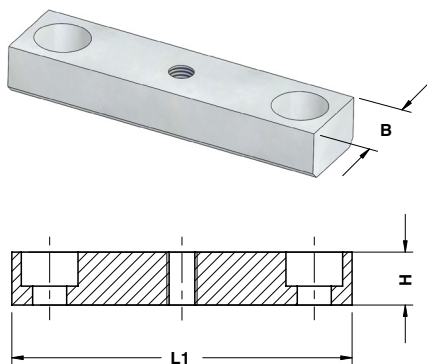

Standard
Mercedes-Benz

ORDER EXAMPLE 	OMCR CODE
	A32.022.050.A

OMCR CODE	SIMILAR TO	B	H	L1	Material
A32.022.050.A	B8 0111 0455258	22 0/+0,01	14	50	CK45
A32.022.090.A	B8 0111 0455442	22 0/+0,01	14	90	CK45
A32.022.150.A	B8 0111 0455443	22 0/+0,01	14	150	CK45
A32.022.240.A	B8 0111 0455444	22 0/+0,01	14	240	CK45
A32.022.240.B	B8 0111 1269325	22 +0,3/+0,4	14	240	CK45
A32.030.150	B8 0111 1197100	30 h11	30	150	St37
A32.030.240	B8 0111 1195191	30 h11	30	240	St37

GUIDE POST - FÜHRUNGSSÄULE - COLONNA GUIDA

Notes

Material: Steel - **HRC:** 60÷62

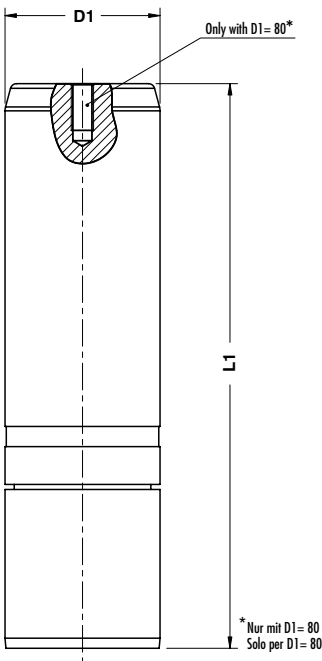

OMCR CODE
A33.040.160

OMCR CODE	SIMILAR TO	D1	L1	OMCR CODE	SIMILAR TO	D1	L1
A33.040.160	B8 0450 0333405	40	160	A33.063.180	B8 0450 0333419	63	180
A33.040.180	B8 0450 0333406	40	180	A33.063.200	B8 0450 0333420	63	200
A33.040.200	B8 0450 0333407	40	200	A33.063.224	B8 0450 0333421	63	224
A33.040.224	B8 0450 0333408	40	224	A33.063.250	B8 0450 0333422	63	250
A33.040.183	B8 0450 0333409	40	250	A33.063.280	B8 0450 0333423	63	280
A33.040.184	B8 0450 0333410	40	280	A33.063.315	B8 0450 0333424	63	315
A33.050.160	B8 0450 0333411	50	160	A33.063.355	B8 0450 0333425	63	355
A33.050.180	B8 0450 0333412	50	180	A33.063.400	B8 0450 0333426	63	400
A33.050.200	B8 0450 0333413	50	200	A33.080.224	B8 0450 0333427	80	224
A33.050.224	B8 0450 0333414	50	224	A33.080.250	B8 0450 0333428	80	250
A33.050.250	B8 0450 0333415	50	250	A33.080.280	B8 0450 0333429	80	280
A33.050.280	B8 0450 0333416	50	280	A33.080.315	B8 0450 0333430	80	315
A33.050.315	B8 0450 0333417	50	315	A33.080.355	B8 0450 0333431	80	355
A33.050.355	B8 0450 0333418	50	355	A33.080.400	B8 0450 0333432	80	400

GUIDE POST - FÜHRUNGSSÄULE - COLONNA GUIDA

Notes

Material: Steel - **HRC:** 60+62

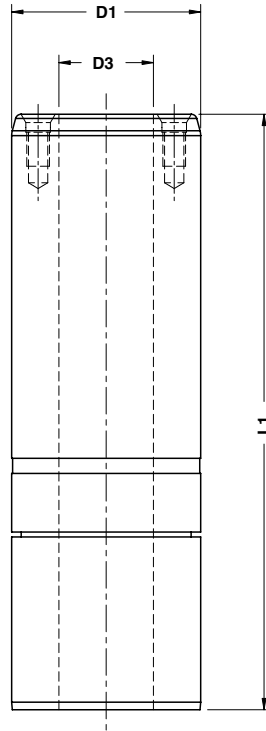

Standard
Mercedes-Benz



OMCR CODE
A34.100.280

OMCR CODE	SIMILAR TO	D1	D3	L1	OMCR CODE	SIMILAR TO	D1	D3	L1
A34.100.280	B8 0450 0333433	100	50	280	A34.125.450	B8 0450 0333439	125	65	450
A34.100.315	B8 0450 0333434	100	50	315	A34.160.400	B8 0450 0584356	160	95	400
A34.100.355	B8 0450 0333435	100	50	355	A34.160.450	B8 0450 0333440	160	95	450
A34.100.400	B8 0450 0333436	100	50	400	A34.160.500	B8 0450 0333441	160	95	500
A34.125.355	B8 0450 0333437	125	65	355	A34.160.560	B8 0450 0333442	160	95	560
A34.125.400	B8 0450 0333438	125	65	400					

LOCATING BLOCK - FANGBACKE - TASSELLO DI CENTRAGGIO

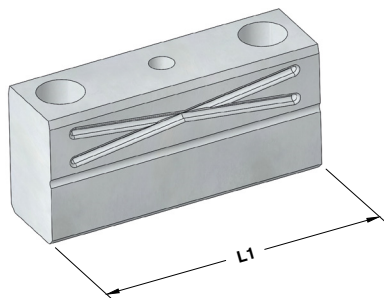

Notes

Material: 16MnCr5

HRC: 60±62

STOCK

	OMCR CODE		
	A44.075.100		
OMCR CODE	SIMILAR TO	L1	
A44.075.100	B8 0467 0091638	100	
A44.075.160	B8 0467 0091639	160	

Standard
Mercedes-Benz

GAGE FOR SENSOR - EINWEISER FÜR TEILLAGEKONTROLLE - RIFERIMENTO PER SENSORE

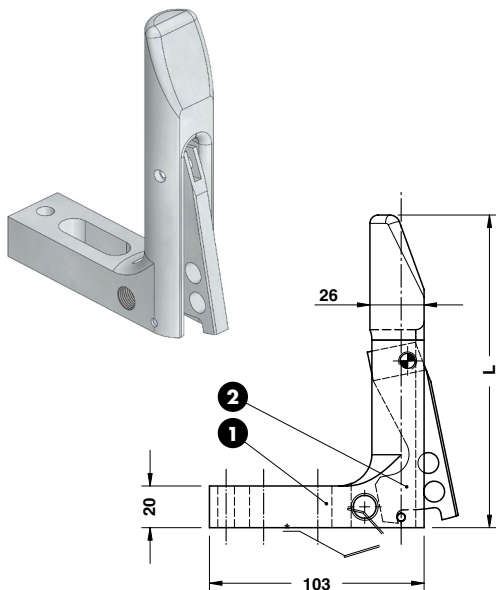

Notes

1 Material: CK60

2 Material: St37 - **HRC:** 58±60

STOCK



*Spring - Feder - Molla

	OMCR CODE		
	A45.030.120		
OMCR CODE	SIMILAR TO	L	
A45.030.120	B8 0541 1049305	120	
A45.030.150	B8 0541 1049306	150	
A45.030.180	B8 0541 1049307	180	
A45.030.250	B8 0541 1049308	250	

SPACER - DISTANZSCHEIBE - DISTANZIALE

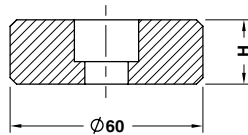
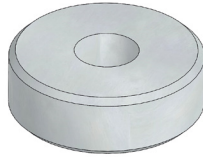

Notes

Material: CK45

STOCK

	OMCR CODE	
	A47.020.060	
OMCR CODE	SIMILAR TO	L
A47.020.060	B8 0550 0333522	20
A47.030.060	B8 0550 0333523	30
A47.040.060	B8 0550 0528689	40

STOP BLOCK - ABSTANDBLOCK - DISTANZIALE

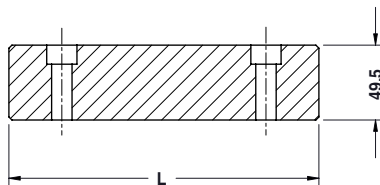
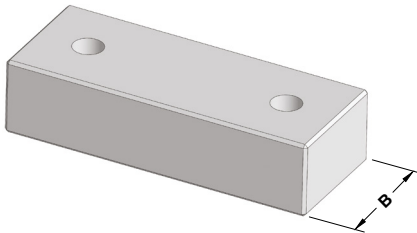

Notes

Material: CK45

STOCK

	OMCR CODE		
	A49.080.155		
OMCR CODE	SIMILAR TO	B	L
A49.080.155	B8 0561 0377769	80	155
A49.080.205	B8 0561 0376641	80	205
A49.100.245	B8 0561 0376642	100	245

LOCATING PIN - ZENTRIERBOLZEN - CENTRAGGIO

Notes

Material: 16MnCr5
HRC: 60÷62

STOCK



OMCR CODE

A50.040.067

OMCR CODE

A50.040.067

SIMILAR TO

B8 0602 0533447

Standard
Mercedes-Benz

SPRING PIN - AUFNAHMEBOLZEN - PERNO PER MOLLA

Notes

Material: CK45

STOCK

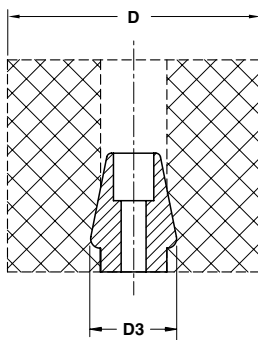

OMCR CODE

A51.028.050

OMCR CODE

A51.028.050

SIMILAR TO

B8 0604 0333552

D

63

D3

28

A51.032.050

B8 0604 0333553

80÷100

32

A51.038.050

B8 0604 0333554

125÷140

38

SPACER - ABSTIMMSCHRAUBE - DISTANZIALE

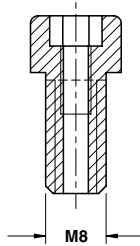

Notes

DIN 912 8.8

STOCK



OMCR CODE

A54.01250.M8

OMCR CODE

SIMILAR TO

A54.01250.M8

B8 1001 0333539

POST RING - SPRENGRING - ANELLO PER COLONNA

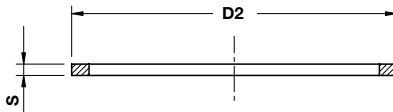
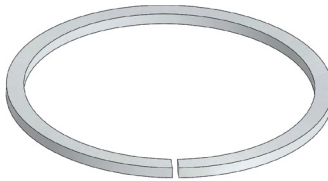

Notes

Material: EN 10270

STOCK

Application example

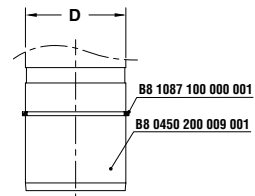

OMCR CODE

A55.040.04300

OMCR CODE	SIMILAR TO	D	D2	S	OMCR CODE	SIMILAR TO	D	D2	S	OMCR CODE	SIMILAR TO	D	D2	S
A55.040.04300	B8 1087 0333184	40	43	1,5	A55.080.08320	B8 1087 0333187	80	83,2	2	A55.040.04300	B8 1087 0333190	160	164,3	2,5
A55.050.05300	B8 1087 0333185	50	53	1,5	A55.100.01038	B8 1087 0333188	100	103,8	2,5					
A55.063.06600	B8 1087 0333186	63	66	1,5	A55.125.01288	B8 1087 0333189	125	128,8	2,5					

ELASTOMER SPRING - ELASTOMERFEDER - MOLLA IN ELASTOMERO

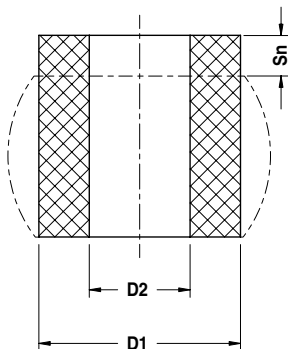

Sn max = 24 mm

Notes
Material: Elastomer 92 SH

STOCK

OMCR CODE
A56.080.040

OMCR CODE	SIMILAR TO	D1	D2
A56.080.040	B8 1123 0377012	80	40

Standard Mercedes-Benz

RETAINER BOLT - HALTEBOLZEN - TIRANTE

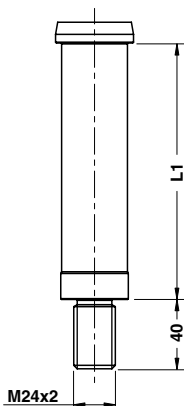

Notes
Material: 42CrMo4
1000÷1200 N/mm²

STOCK

OMCR CODE
A57.038.048

OMCR CODE	SIMILAR TO	L1	OMCR CODE	SIMILAR TO	L1	OMCR CODE	SIMILAR TO	L1
A57.038.048	B8 2002 0373389	48	A57.038.148	B8 2002 0373405	148	A57.038.248	B8 2002 0373412	248
A57.038.068	B8 2002 0373390	68	A57.038.168	B8 2002 0373406	168	A57.038.268	B8 2002 0373413	268
A57.038.088	B8 2002 0373391	88	A57.038.188	B8 2002 0373407	188	A57.038.288	B8 2002 0373414	288
A57.038.108	B8 2002 0373392	108	A57.038.208	B8 2002 0373409	208			
A57.038.128	B8 2002 0373393	128	A57.038.228	B8 2002 0373410	228			

UPPER AIR CUSHION PIN – OBERLUFTBOLZEN – CANDELA SUPERIORE

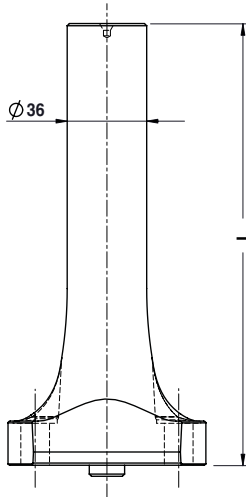

Notes

Material: 42CrMo4
800±1000 N/mm²

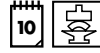

ORDER EXAMPLE	OMCR CODE
	A58.036.150

OMCR CODE	SIMILAR TO	L
A58.036.150	B8 2002 1152051	150
A58.036.175	B8 2002 1152052	175
A58.036.200	B8 2002 1152053	200
A58.036.225	B8 2002 1152054	225
A58.036.250	B8 2002 1152055	250
A58.036.275	B8 2002 1410472	275
A58.036.300	B8 2002 1410473	300
A58.036.325	B8 2002 1410474	325
A58.036.350	B8 2002 1410475	350

CAM ROLLER - ROLLENBOCK - SUPPORTO CON RULLO

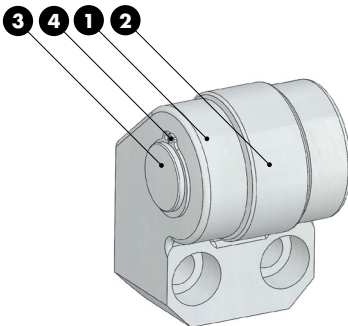

Notes

- 1 **Material:** 42CrMo4
- 2 NUTR 2552
- 3 **Material:** X210Cr12 - HRC 60±62
- 4 E25 DIN 471



ORDER EXAMPLE	OMCR CODE
	A59.025.052

OMCR CODE	SIMILAR TO
A59.025.052	B8 7466 033319

GAGE - EINWEISER - RIFERIMENTO

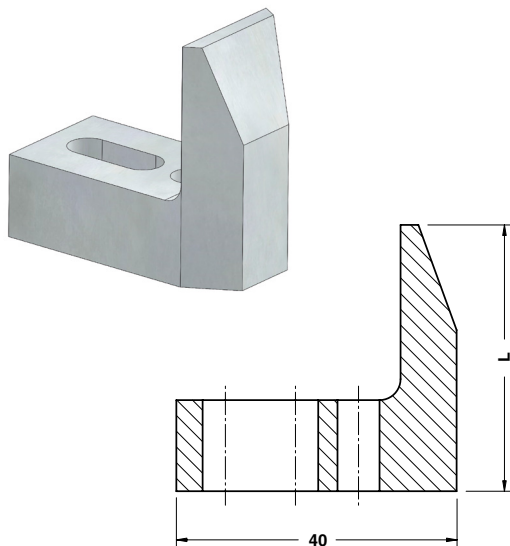

Notes

Material: 21MnCr5 - **HRC:** 58÷60

STOCK



OMCR CODE

C10.18.028

OMCR CODE	SIMILAR TO	L
C10.18.028	B8 0541 1086747	28
C10.18.038	B8 0541 1086749	38
C10.18.048	B8 0541 1086750	48
C10.18.058	B8 0541 138392	58
C10.18.068	B8 0541 138393	68
C10.18.078	B8 0541 138395	78

Standard
Mercedes-Benz

LOCATING CONE - KEGELAUFSATZ - CONO DI CENTRAGGIO

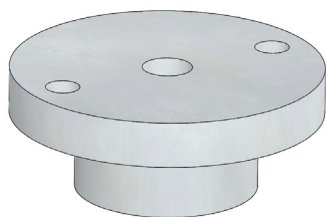

FORM A

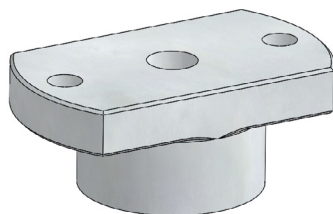

FORM B

Notes

Material: 16MnCr5 - **HRC:** 60÷64

STOCK



OMCR CODE

A53.058.100

OMCR CODE	SIMILAR TO	FORM
C11.09.10080A-01	B8 0624 0372844	A
C11.09.10080B-01	B8 0624 0345931	B

LOCATING CONE - ZENTRIERZAPFEN - CONO DI CENTRAGGIO



FORM A

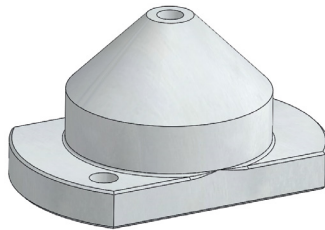

FORM B

Notes

Material: 16MnCr5 - **HRC:** 60÷64

STOCK



OMCR CODE	OMCR CODE
	C11.11.10080A-02

OMCR CODE	SIMILAR TO	FORM
C11.11.10080A-02	B8 0604 0372845	A
C11.11.10080B-02	B8 0604 0345936	B

BACKING PLATE - DRUCKPLATTE - REAZIONE PER CILINDRO

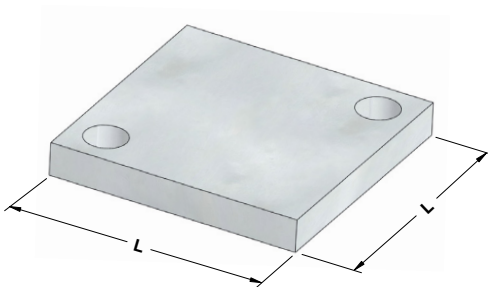

Notes

Material: 90MnCrV8
HRC: 49÷52

STOCK



OMCR CODE	OMCR CODE
	C12.24.09009012

OMCR CODE	SIMILAR TO	L
C12.24.09009012	B8 0561 0347055	90
C12.24.06006012	B8 0561 0544586	60
C12.24.10010012	B8 0561 0343592	100

WEAR PLATE SELF-LUBRICATING VDI 3357
GLEITPLATTE BRONZE MIT FESTSCHMIERSTOFF VDI 3357
PIASTRA GUIDA AUTOLUBRIFICANTE VDI 3357

Notes

Material: Bronze + Graphite
HB > 190

STOCK

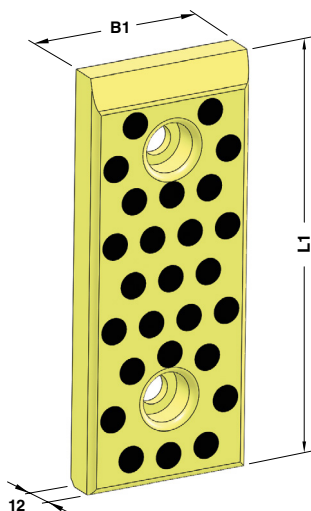

Standard Mercedes-Benz

	OMCR CODE
	E40.06.03012080

OMCR CODE	SIMILAR TO	B1	L1	OMCR CODE	SIMILAR TO	B1	L1
E40.06.03012080	B8 0460 0333603	30	80	E40.06.06012080	B8 0460 0333613	60	80
E40.06.03012100	B8 0460 0333604	30	100	E40.06.06012100	B8 0460 0333614	60	100
E40.06.03012125	B8 0460 0333605	30	125	E40.06.06012125	B8 0460 0333615	60	125
E40.06.03012160	B8 0460 0333606	30	160	E40.06.06012160	B8 0460 0333616	60	160
E40.06.03012200	B8 0460 0333607	30	200	E40.06.06012200	B8 0460 0333617	60	200
E40.06.04012080	B8 0460 0333608	40	80	E40.06.08012080	B8 0460 0789442	80	80
E40.06.04012100	B8 0460 0333609	40	100	E40.06.08012100	B8 0460 0789444	80	100
E40.06.04012125	B8 0460 0333610	40	125	E40.06.08012125	B8 0460 0789446	80	125
E40.06.04012160	B8 0460 0333611	40	160	E40.06.08012160	B8 0460 0789447	80	160
E40.06.04012200	B8 0460 0333612	40	200	E40.06.08012200	B8 0460 0789448	80	200

WEAR PLATE SELF-LUBRICATING VDI 3357
GLEITPLATTE BRONZE MIT FESTSCHMIERSTOFF VDI 3357
PIASTRA GUIDA AUTOLUBRIFICANTE VDI 3357

Notes

Material: Bronze + Graphite
HB > 190

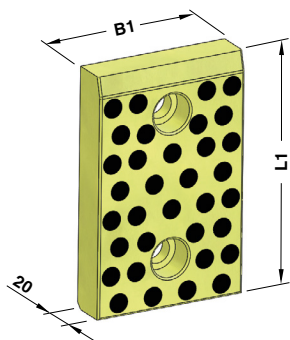

FORM A

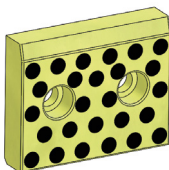

FORM B

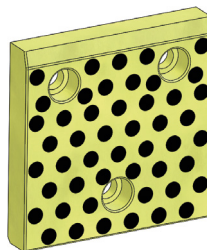

FORM C

	OMCR CODE
	E40.12.05020080

OMCR CODE	SIMILAR TO	B1	L1	FORM	OMCR CODE	SIMILAR TO	B1	L1	FORM
E40.12.05020080	B8 0460 0332587	50	80	A	E40.12.10020160	B8 0460 0332602	100	160	A
E40.12.05020100	B8 0460 0332588	50	100	A	E40.12.10020200	B8 0460 0332603	100	200	A
E40.12.05020125	B8 0460 0332589	50	125	A	E40.12.12520050	B8 0460 0332604	125	50	B
E40.12.05020160	B8 0460 0332590	50	160	A	E40.12.12520080	B8 0460 0332605	125	80	B
E40.12.05020200	B8 0460 0332591	50	200	A	E40.12.12520100	B8 0460 0332606	125	100	C
E40.12.08020050	B8 0460 0332592	80	50	B	E40.12.12520125	B8 0460 0332607	125	125	C
E40.12.08020080	B8 0460 0332593	80	80	A	E40.12.12520160	B8 0460 0332608	125	160	C
E40.12.08020100	B8 0460 0332594	80	100	A	E40.12.12520200	B8 0460 0332609	125	200	C
E40.12.08020125	B8 0460 0332595	80	125	A	E40.12.16020050	B8 0460 0332610	160	50	B
E40.12.08020160	B8 0460 0332596	80	160	A	E40.12.16020080	B8 0460 0332611	160	80	B
E40.12.08020200	B8 0460 0332597	80	200	A	E40.12.16020100	B8 0460 0332612	160	100	C
E40.12.10020050	B8 0460 0332598	100	50	B	E40.12.16020125	B8 0460 0332613	160	125	C
E40.12.10020080	B8 0460 0332599	100	80	B	E40.12.16020160	B8 0460 0332614	160	160	C
E40.12.10020100	B8 0460 0332600	100	100	A	E40.12.16020200	B8 0460 0332615	160	200	C
E40.12.10020125	B8 0460 0332601	100	125	A					

CAM DWELL WEAR PLATE SELF-LUBRICATING UBERLAUFKEILE BRONZE MIT FESTSCHMIERSTOFF CUNEO AUTOLUBRIFICANTE

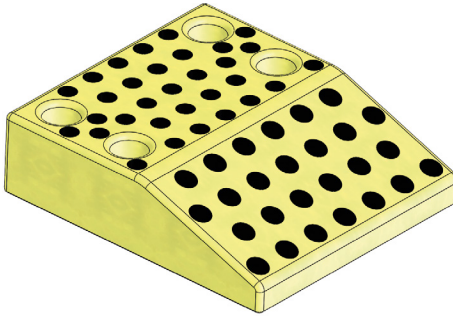

Notes

Material: Bronze + Graphite
HB > 190

STOCK



Standard
Mercedes-Benz

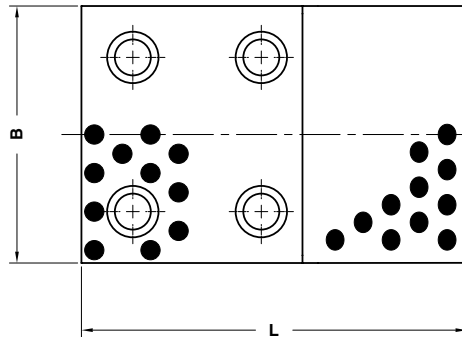
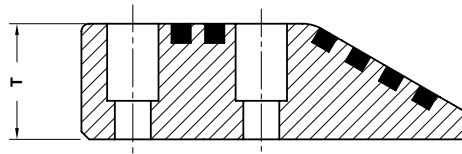

	OMCR CODE
	E44.12.10045150

OMCR CODE	SIMILAR TO	B	L	T
E44.12.10045150	B8 0467 0528752	100	150	45
E44.12.10060170	B8 0467 0528753	100	170	60
E44.12.12545150	B8 0467 0528754	125	150	45
E44.12.12560170	B8 0467 0528755	125	170	60
E44.12.15045150	B8 0467 0528756	150	150	45
E44.12.15060170	B8 0467 0528757	150	170	60

CAM DWELL STEEL
UBERLAUFKEILE STAHL
CUNEO IN ACCIAIO

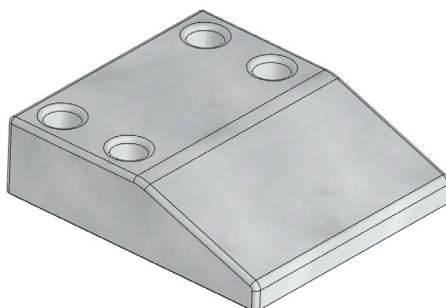

Notes

Material: X155CrVMo121KU

HRC: 58÷62

STOCK

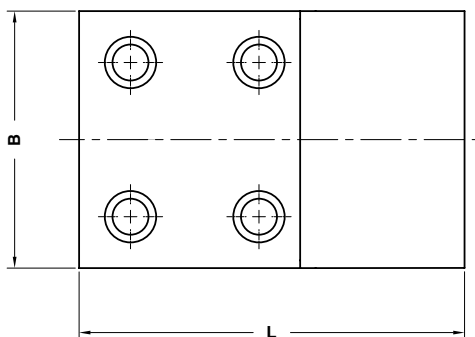
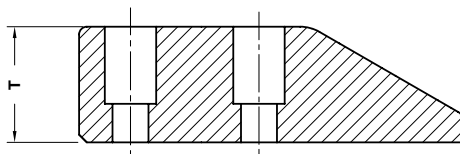

OMCR CODE

E44.13.10045150

OMCR CODE	SIMILAR TO	B	L	T
E44.13.10045150	B8 0467 0528447	100	150	45
E44.13.10060170	B8 0467 0528448	100	170	60
E44.13.12545150	B8 0467 0528449	125	150	45
E44.13.12560170	B8 0467 0528450	125	170	60
E44.13.15045150	B8 0467 0528451	150	150	45
E44.13.15060170	B8 0467 0528452	150	170	60

GUIDE POST - FÜHRUNGSSÄULE - COLONNA GUIDA



Notes
Material: Steel - **HRC:** 60÷62

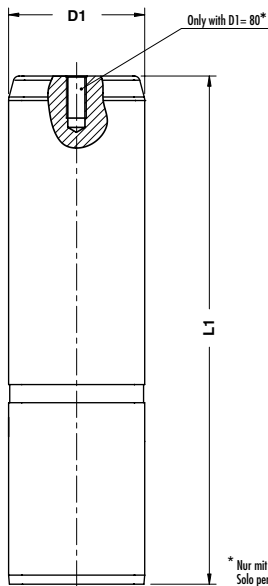

OMCR CODE
E45.10.025125

OMCR CODE	SIMILAR TO	D1	L1	OMCR CODE	SIMILAR TO	D1	L1
E45.10.025125	B8 0450 0528716	25	125	E45.10.050250	B8 0450 0332531	50	250
E45.10.025140	B8 0450 0528717	25	140	E45.10.050280	B8 0450 0332532	50	280
E45.10.025160	B8 0450 0528718	25	160	E45.10.050315	B8 0450 0332533	50	315
E45.10.025180	B8 0450 0528719	25	180	E45.10.050355	B8 0450 0332639	50	355
E45.10.032140	B8 0450 0531827	32	140	E45.10.063180	B8 0450 0332534	63	180
E45.10.032160	B8 0450 0332519	32	160	E45.10.063200	B8 0450 0332535	63	200
E45.10.032180	B8 0450 0332520	32	180	E45.10.063224	B8 0450 0332536	63	224
E45.10.032200	B8 0450 0332521	32	200	E45.10.063250	B8 0450 0332537	63	250
E45.10.040140	B8 0450 0531828	40	140	E45.10.063280	B8 0450 0332538	63	280
E45.10.040160	B8 0450 0332522	40	160	E45.10.063315	B8 0450 0332539	63	315
E45.10.040180	B8 0450 0332523	40	180	E45.10.063355	B8 0450 0332540	63	355
E45.10.040200	B8 0450 0332524	40	200	E45.10.063400	B8 0450 0332541	63	400
E45.10.040224	B8 0450 0332525	40	224	E45.10.080224	B8 0450 0332542	80	224
E45.10.040250	B8 0450 0332526	40	250	E45.10.080250	B8 0450 0332543	80	250
E45.10.040280	B8 0450 0333401	40	280	E45.10.080280	B8 0450 0332544	80	280
E45.10.050160	B8 0450 0332527	50	160	E45.10.080315	B8 0450 0332545	80	315
E45.10.050180	B8 0450 0332528	50	180	E45.10.080355	B8 0450 0332546	80	355
E45.10.050200	B8 0450 0332529	50	200	E45.10.080400	B8 0450 0332547	80	400
E45.10.050224	B8 0450 0332530	50	224				

Standard Mercedes-Benz

GUIDE POST - FÜHRUNGSSÄULE - COLONNA GUIDA

Notes

Material: Steel - **HRC:** 60÷62

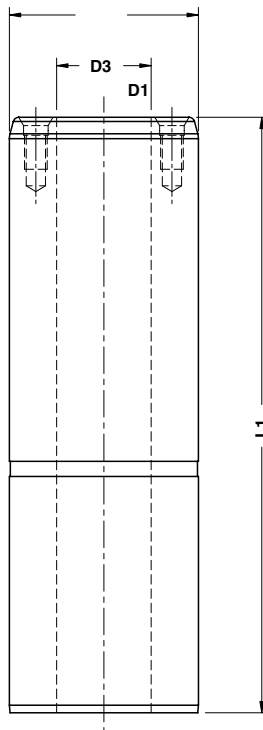

OMCR CODE

E45.10.100280W

OMCR CODE	SIMILAR TO	D1	D3	L1	OMCR CODE	SIMILAR TO	D1	D3	L1
E45.10.100280W	B8 0450 0332548	100	50	280	E45.10.125450W	B8 0450 0332554	125	65	450
E45.10.100315W	B8 0450 0332549	100	50	315	E45.10.160400W	B8 0450 0584357	160	95	400
E45.10.100355W	B8 0450 0332550	100	50	355	E45.10.160450W	B8 0450 0332555	160	95	450
E45.10.100400W	B8 0450 0332551	100	50	400	E45.10.160500W	B8 0450 0332556	160	95	500
E45.10.125355W	B8 0450 0332552	125	65	355	E45.10.160560W	B8 0450 0332557	160	95	560
E45.10.125400W	B8 0450 0332553	125	65	400					

E46.10

NOT HOMOLOGATED IN MERCEDES-BENZ



BUSH SELF-LUBRICATING DIN 9834 FÜHRUNGSBUCHSE DIN 9834 BOCCOLA AUTOLUBRIFICANTE DIN 9834

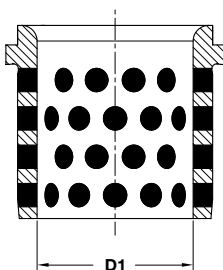

Notes

Material: Bronze + Graphite**HB** > 190

STOCK



OMCR CODE

E46.10.025040

OMCR CODE	SIMILAR TO	D1
E46.10.025040	B8 0441 0331931	25
E46.10.032050	B8 0441 0331932	32
E46.10.040063	B8 0441 0331933	40
E46.10.050071	B8 0441 0331934	50
E46.10.063080	B8 0441 0331935	63
E46.10.080100	B8 0441 0331936	80
E46.10.100125	B8 0441 0331937	100
E46.10.125160	B8 0441 0331938	125
E46.10.160200	B8 0441 0331939	160

Standard
Mercedes-Benz

E47.10

NOT HOMOLOGATED IN MERCEDES-BENZ



TOE CLAMP - HALTESTÜCK - RITEGNO PER BOCCOLA

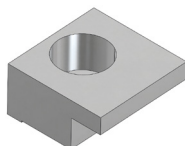

Notes

Material: CK45

Application example

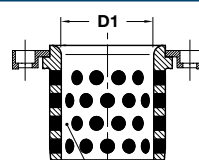

B8 0441 0331931-0331939

STOCK



OMCR CODE

E47.10.202010

OMCR CODE	SIMILAR TO	D1
E47.10.202010	B8 0161 03311940	25-50
E47.10.323216	B8 0161 03311941	63-160

