



Die Components Normalien Componenti

FCA

FIAT CHRYSLER AUTOMOBILES

















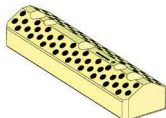

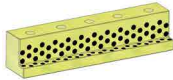
OMCR[®]
STANDARD DIE COMPONENTS

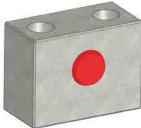

MAIN
INDEX

<p>010.90.05</p> 	<p>010.90.05</p> 	<p>010.90.10</p> 	<p>010.90.20</p> 	<p>010.90.50</p> 
<p>Stamp Buchstabenstempel Gruppo punzone</p>	<p>Backing plate Druckplatte Distanziale</p>	<p>Stamp Buchstabenstempel Gruppo punzone marchio emblematico</p>	<p>Trademark stamp Buchstabenstempel Punzone marchio</p>	<p>Visual locator punch Endkontrollstempel Punzone di visualizzazione</p>
206	206	207	208	208
<p>010.90.55</p> 	<p>010.90.60</p> 	<p>010.90.85</p> 	<p>025.90.05</p> 	<p>025.90.10</p> 
<p>Adjustment plate Scheibe Rondella di registro</p>	<p>Key Passfeder Chiavetta</p>	<p>Locating cone Kegeldistanz Cono di centraggio</p>	<p>Ball caster Kugellrollensystem Sfera portante</p>	<p>Trestle guide group Führungsgruppe Gruppo guida traliccio</p>
209	209	210	210	211
<p>025.90.35</p> 	<p>025.90.40</p> 	<p>025.90.45</p> 	<p>025.90.55</p> 	<p>025.90.60</p> 
<p>Coil guide roller Bandführung Guida nastro fisso</p>	<p>Coil guide roller Bandführung Guida nastro mobile</p>	<p>Roller group Förderrolle Gruppo rullini</p>	<p>Roller Rolle Rotella</p>	<p>Spring group Federeinheit Gruppo molla</p>
212	212	213	214	214
<p>025.90.65</p> 	<p>025.90.70</p> 	<p>025.90.75</p> 	<p>025.90.80</p> 	<p>025.90.85</p> 
<p>Spring group Federeinheit Gruppo molla</p>	<p>Lifter stop Anschlag Heber Gruppo arresto traliccio</p>	<p>Spring group Federeinheit Gruppo molla</p>	<p>Stripper for blanking dies Abstreifer für platinenschnitte Estrattore per stampi tranciasviluppo</p>	<p>Roller stock lifter Federnde lauffrolle Rullino sollevamento nastro</p>
215	215	216	216	217

<p>025.90.90</p> 	<p>025.90.95</p> 	<p>025.90.95</p> 	<p>025.90.105</p> 	<p>025.90.155</p> 
<p>Spring group Federeinheit Gruppo molla</p> <p>217</p>	<p>Pad retainer Zugbolzensatz Gruppo di arresto</p> <p>218</p>	<p>Pad retainer Zugbolzensatz Gruppo di arresto</p> <p>218</p>	<p>Roller Rolle Gruppo rullo di evacuazione</p> <p>219</p>	<p>Guide post group Führungssäule mit führungs-lager Gruppo colonna</p> <p>220</p>
<p>025.90.160</p> 	<p>030.90.05</p> 	<p>030.90.10</p> 	<p>030.90.15</p> 	<p>030.90.20</p> 
<p>Spring group Federeinheit Gruppo molla</p> <p>221</p>	<p>Compensation block Abstandsblock Tassello di compensazione</p> <p>222</p>	<p>Spacer plate toothed Distanzplatte gezahnt Tassello di compensazione</p> <p>222</p>	<p>Pre-centering punch Stempelvorzentrierung Precentraggio punzone</p> <p>223</p>	<p>Lower air cushion pin Unterluftbolzen Candela inferiore</p> <p>223</p>
<p>030.90.40</p> 	<p>030.90.41</p> 	<p>030.90.45</p> 	<p>030.90.165</p> 	<p>040.90.10</p> 
<p>Gage Einweiser Riferimento</p> <p>224</p>	<p>Gage hardened Einweiser gehärtet Riferimento indurito</p> <p>224</p>	<p>Gage for sensor Einweiser für teillagekontrolle Riferimento per sensore</p> <p>225</p>	<p>Air relief tubing Tube Tubetto sfogo aria</p> <p>225</p>	<p>Flange lifter Abstreifer Sflangiator</p> <p>226</p>
<p>045.90.90</p> 	<p>050.85.10</p> 	<p>050.90.30</p> 	<p>050.90.30</p> 	<p>050.90.30</p> 
<p>Key Passfeder Chiavetta</p> <p>226</p>	<p>Roller cam units CRX Rollenschieber CRX Camma a rullo CRX</p> <p>227</p>	<p>Aerial cam unit CHD Oben hängender schieber CHD Unità a camme sospesa CHD</p> <p>228</p>	<p>Aerial cam unit CHV Oben hängender schieber CHV Unità a camme sospesa CHV</p> <p>229</p>	<p>Aerial cam unit CLB Oben hängender schieber CLB Unità a camme sospesa CLB</p> <p>230</p>

<p>050.90.65</p>  <p>Distance plate for wear plate Höhenausgleich für gleitplatte Distanziale per piastra</p> <p>231</p>	<p>050.90.70</p>  <p>Wear plate self-lubricating Gleitplatte bronze mit festschmierstoff Piastra guida autolubrificante</p> <p>231</p>	<p>050.90.75</p>  <p>Wear plate steel Gleitplatte stahl Piastra guida in acciaio</p> <p>232</p>	<p>050.90.90</p>  <p>Wear plate steel Deckleiste Stahl Piastra guida in acciaio</p> <p>232</p>	<p>050.90.95</p>  <p>Wear plate steel Deckleiste Stahl Piastra guida in acciaio</p> <p>233</p>
<p>050.90.105</p>  <p>"V" driver steel Prismenführung Guida a "V" in acciaio</p> <p>233</p>	<p>050.90.110</p>  <p>"V" driver self-lubricating Prismenführung bronze mit festschmierstoff Guida a "V" autolubrificante</p> <p>234</p>	<p>050.90.115</p>  <p>Distance plate for "V" driver Höhenausgleich für Prismenführung Distanziale per guida a "V"</p> <p>234</p>	<p>050.90.120</p>  <p>Angular guide Winkelleiste Guida angolare</p> <p>235</p>	<p>050.90.150</p>  <p>Fork pawl Befestigungsplatte Forcella nottolino</p> <p>236</p>
<p>050.90.177</p>  <p>Positive return plate Zwangsrückholer Gancio di sicurezza</p> <p>236</p>	<p>050.90.200</p>  <p>Stop block Anschlag Arresto</p> <p>237</p>	<p>050.90.205</p>  <p>Slide stop block Schieberanschlag Arresto slitta</p> <p>237</p>	<p>065.90.05</p>  <p>Retainer bolt Zugbolzensatz Gruppo tirante</p> <p>238</p>	<p>065.90.05</p>  <p>Retainer bolt Zugbolzensatz Gruppo tirante</p> <p>239</p>
<p>065.90.05</p>  <p>Retainer bolt Zugbolzensatz Gruppo tirante</p> <p>240</p>	<p>065.90.30</p>  <p>Retainer bolt Zugbolzensatz Gruppo tirante</p> <p>241</p>	<p>065.90.35</p>  <p>Retainer bolt Zugbolzensatz Gruppo tirante</p> <p>242</p>	<p>065.90.40</p>  <p>Retainer bolt Zugbolzensatz Gruppo tirante</p> <p>243</p>	<p>065.90.45</p>  <p>Retainer bolt Zugbolzensatz Gruppo tirante</p> <p>244</p>

065.90.65  Shock absorber Halteelement Ammortizzatore 245	065.90.70  Guide post DIN 9833 Führungssäule DIN 9833 Colonna guida DIN 9833 246	065.90.70  Guide post DIN 9833 Führungssäule DIN 9833 Colonna guida DIN 9833 247	065.90.75  Guide post Führungssäule Colonna guida 248	065.90.80  Guide post DIN 9833 Führungssäule DIN 9833 Colonna guida DIN 9833 249
065.90.85  Bush self-lubricating DIN 9834 Führungsbuchse DIN 9834 Boccola autolubrificante DIN 9834 250	065.90.90  Toe clamp Haltestück Ritegno per boccola 250	065.90.96  Bush self lubricating Führungsbuchse Boccola autolubrificante 251	065.90.102  Toe clamp Haltestück Ritegno per boccola 251	065.90.120  Guide bar self-lubricating VDI 3357 Führungsleite bronze mit festschmierstoff VDI 3357 Lardone autolubrificante VDI 3357 252
065.90.120  Wear plate steel VDI 3357 Gleitplatte stahl VDI 3357 Piastra guida in acciaio VDI 3357 253	065.90.125  Distance plate for wear plate Höhenausgleich für gleitplatte Distanziale per piastra 254	065.90.130  Pad retainer pin Steckbolzen Perno di arresto 255	065.90.190  Locating pin Zentrierbolzen Centraggio 255	065.90.195  Balance block Distanzstück Distanziale 256
065.90.200  Guide pin retainer plate Sicherungsplatte Ritegno per colonna 256	075.90.45  Spring plunger Federne druckstücke Espulsore a molla 257	075.90.110  Pressure plate Druckplatte Piastra di reazione 258	075.90.115  Pressure plate Druckplatte Piastra di reazione 258	075.90.120  Pressure plate Druckplatte Piastra di reazione 259

080.90.60	080.90.75	080.90.90	085.90.135	085.90.140
				
Clamp Befestigungselement Morsetto	Sleeve Führungseinheit Canotto guida	Elastomer cap Elastomerdruckstück Puntalino elastico	Coupling plate Befestigungsplatte Staffa di reazione	Coupling nut Kupplungsmutter Aggancio staffa
259	260	261	261	262
095.90.10	095.90.20	095.90.25	095.90.30	095.90.30
				
Threaded steel insert Gewindeinsatz Aus Stahl Inserto filettato in acciaio	Elastomer spring Elastomerfeder Molla in elastomero	Elastomer spring pin Aufnahmebolzen Perno per molle in elastomero	Replacement lifting pin for lifting bracket Ersatztragbolzen für tragwange Perno di ricambio per staffa di sollevamento	Replacement lifting pin for lifting bracket Ersatztragbolzen für tragwange Perno di ricambio per staffa di sollevamento
262	263	263	264	265
095.90.35	095.90.40	095.90.60	095.90.71	095.90.75
				
Lifting pin Tragbolzen mit fallringsicherung Perno di sollevamento	Bush for lifting pin Buchse für Tragbolzen Boccola per perno di sollevamento	Lifting bracket Tragwange mit fallringsicherung Staffa di sollevamento	Lifting bracket with pin and locating pins Tragwange mit Tragbolzen und Zentrierbolzen Staffa di sollevamento completa di perno e centraggi	Lifting pin Tragbolzen mit fallringsicherung Perno di sollevamento
266	267	268	269	270
095.90.75	STQ 10012 - BR	STQ 10012 - ACC	STQ 10012 - TIPO	STQ 10012 - BR
				
Lifting pin Tragbolzen mit fallringsicherung Perno di sollevamento	Wear plate self-lubricating Gleitplatte bronze mit festschmierstoff Piastra guida autolubrificante	Wear plate steel Gleitplatte stahl Piastra guida in acciaio	Distance plate for wear plate Höhenausgleich für gleitplatte Distanziale per piastra	Guide bar self-lubricating Führungsleite bronze mit festschmierstoff Lardone autolubrificante
271	272	273	274	275

STQ 10012 - ACC	STQ 20027 - RIF_M18	STQ 40005 - ST	STQ 40005 - PIA-PA	STQ 40005 - PIA-PA
				
Guide bar steel Führungsleite stahl Lardone in acciaio	Front gage Einlaufanschlag Portasensore	Bracket for clamps Klammern für clamps Staffe per clamps	Plate for clamps Haltestücke für clamps Piastrina per staffe	Plate for clamps Haltestücke für clamps Piastrina per staffe
275	276	277	278	278
STQ 40005 - PIA-PA	STQ 40005 - PIA-PR	STQ 40007 - PFC	STQ 40010 - CNT	STQ 40011 - CTN
				
Plate for clamps Haltestücke für clamps Piastrina per staffe	Plate for clamps Haltestücke für clamps Piastrina per staffe	Visual locator punch Endkontrollstempel Punzone di visualizzazione	Locating Zentrierung Centraggio stampo	Stop block Anschlag Fine corsa diritto e a "V"
279	279	280	280	281
STQ 40013 - CH				
				
Key Passfeder Chiavetta di reazione				
281				

STAMP - BUCHSTABENSTEMPEL - GRUPPO PUNZONE

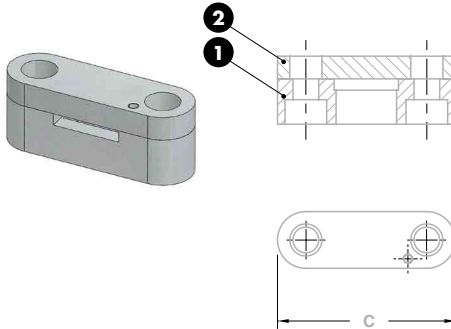

Notes

1 2 Material: CK45

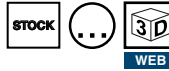

ORDER EXAMPLE		FCA CODE	
		GRLO_4P_163247	
FCA CODE	C	Nr. of Punch	
GRLO_3P_123045	45	3	
GRLO_4P_163247	47	4	
GRLO_8P_324863	63	8	

BACKING PLATE - DRUCKPLATTE - DISTANZIALE

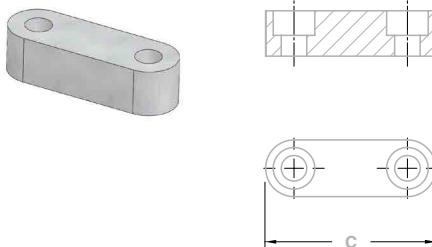

Notes

Material: 90MnVCr8KU - HRC: 56÷58



ORDER EXAMPLE		FCA CODE	
		TCON_4P_163247	
FCA CODE	C	Nr. of punch	
TCON_3P_123045	45	3	
TCON_4P_163247	47	4	
TCON_8P_324863	63	8	

STAMP - BUCHSTABENSTEMPEL - PUNZONE MARCHIO EMBLEMATICO

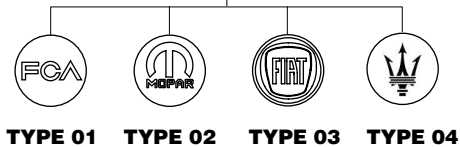
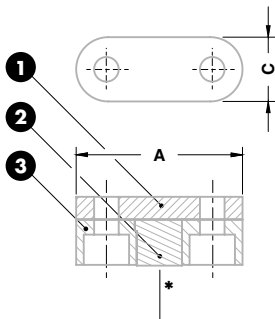

Notes

1 2
Material: 90MnCrV8 - **HRC:** 54÷56

3 **Material:** 36CrNiMo4 - **HRC:** 48÷50



* Specify the type of trademark punch
 Typ Markenstempel angeben
 Specificare il tipo di punzone marchio

Standard FCA

ORDER EXAMPLE	FCA CODE	TYPE
	GRME_N15052022	02

FCA CODE	A	C
GRME_N10044017	44	17
GRME_N15052022	52	22

TRADEMARK STAMP - BUCHSTABENSTEMPEL - PUNZONE MARCHIO

TYPE 01

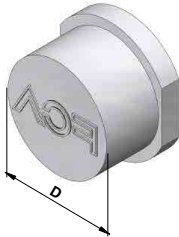

TYPE 02



TYPE 03



TYPE 04



Notes

Material: 90MnV8



WEB



COMMODITY CODE
90-720-0021

COMMODITY CODE	D	TYPE
90-720-0023	12	01
90-720-0020	17	01
90-720-0022	12	02
90-720-0019	17	02
90-720-0021	12	03
90-720-0018	17	03
PTM-R-MASERATI_V01	12	04
PTM-R-MASERATI_V02	17	04

VISUAL LOCATOR PUNCH - ENDKONTROLLSTEMPEL - PUNZONE DI VISUALIZZAZIONE

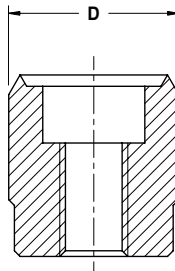
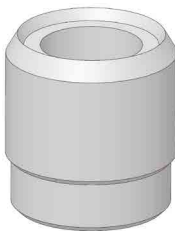

Notes

Material: X155CrVNo121

HRC: 58÷60



WEB



COMMODITY CODE
21-750-0028

COMMODITY CODE	D
21-750-0019	13
21-750-0028	15
21-750-0038	18
21-750-0048	21

ADJUSTMENT PLATE - SCHEIBE - RONDELLA DI REGISTRO

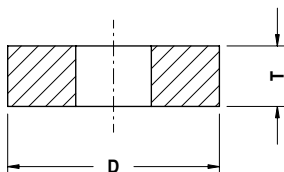
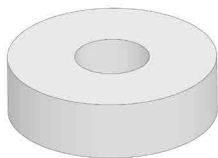

Notes

Material: 42CrMo4



ORDER EXAMPLE	COMMODITY CODE	
	19-010-0119	
COMMODITY CODE	D	T
19-010-0121	12	3
19-010-0119	14	4
19-010-0118	17.5	4
19-010-0117	20.5	4

Standard FCA

KEY - PASSFEDER - CHIAVETTA DI REAZIONE

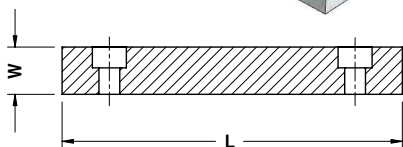
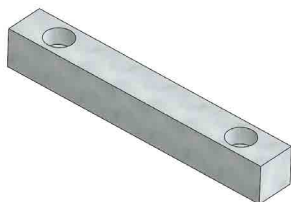
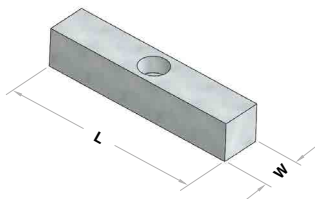

Notes

Material: CK45



ORDER EXAMPLE	COMMODITY CODE		
	19-010-9430		
COMMODITY CODE	L	W	Holes
19-010-0089	80	25	1
19-010-9430	125	25	1
19-010-9431	180	25	2
19-010-0088	80	30	1
19-010-9432	125	30	1
19-010-9433	180	30	2

LOCATING CONE - KEGELDISTANZ - CONO DI CENTRAGGIO

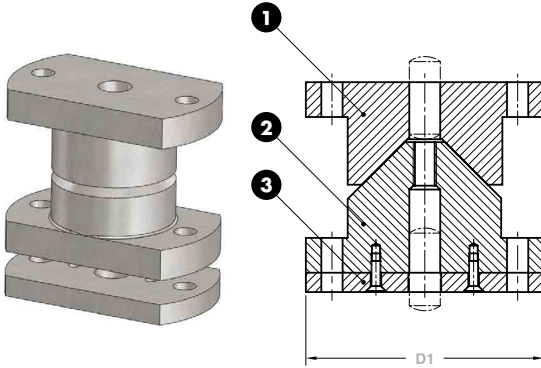

Notes

1 2

Material: 16MnCr5 - HRC: 60÷623 **Material:** CK45

STOCK



WEB

ORDER
EXAMPLE

FCA CODE

CN_120_B

FCA CODE	COMMODITY CODE	D1
CN_100_B	19-010-0082	100
CN_120_B	19-010-0085	120

BALL CASTER - KUGELROLLENSYSTEM - SFERA PORTANTE



Notes

Material: Steel

STOCK



WEB

ORDER
EXAMPLE

FCA CODE

SF_KU30

FCA CODE
SF_KU30

TRESTLE GUIDE GROUP - FÜHRUNGSGRUPPE - GRUPPO GUIDA TRALICCIO

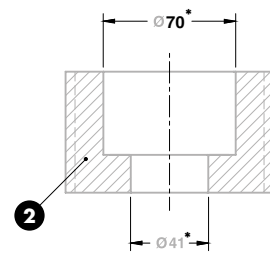
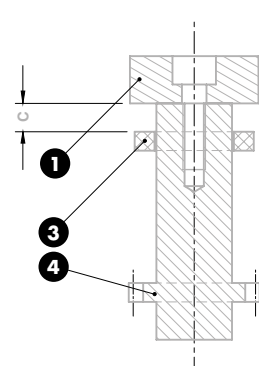
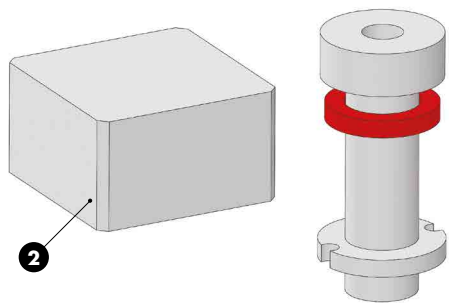

* To be performed after assembling with trestle.
 Muss nach dem Zusammenbau mit der Schiene durchgeführt werden.
 Da eseguire dopo assemblaggio con traliccio.

Notes

- 1 2 Material: CK45
- 3 Material: Urelast 92 SH
- 4 Material: 16MnCr5 - HRC: 58÷60

Application example

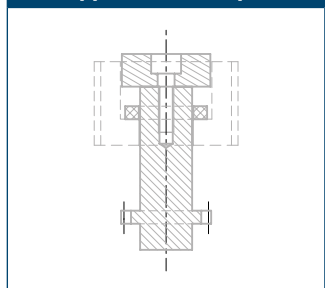

Standard FCA

	FCA CODE
	GRG_TRA_C25
FCA CODE	C
GRG_TRA_C15	15
GRG_TRA_C25	25
GRG_TRA_C30	50

COIL GUIDE ROLLER - BANDFÜHRUNG - GUIDA NASTRO FISSO

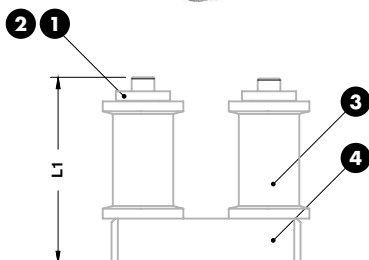
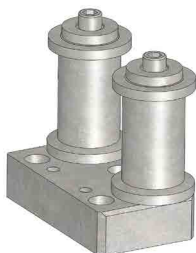

Notes

- 1 2 Material:** CK45
- 3 Material:** 16MnCr5 - HRC: 58÷60
- 4 Material:** Si37



ORDER EXAMPLE	FCA CODE
	GUN_F_73159

FCA CODE	L1	Stroke
GUN_F_55141	141	13 - 23
GUN_F_73159	159	48

COIL GUIDE ROLLER - BANDFÜHRUNG - GUIDA NASTRO MOBILE

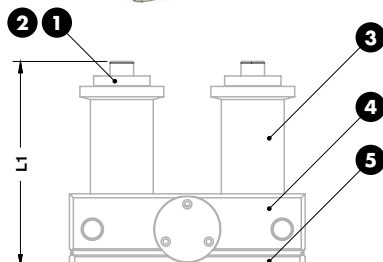
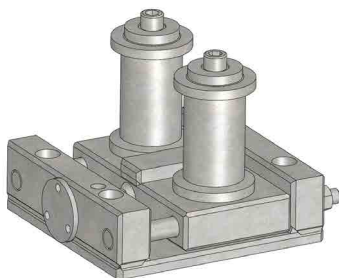

Notes

- 1 2 Material:** CK45
- 3 Material:** 16MnCr5 - HRC: 58÷60
- 4 5 Material:** Si37



ORDER EXAMPLE	FCA CODE
	GUN_M_73157

FCA CODE	L1	Stroke
GUN_M_55150	150	13
GUN_M_73157	157	23

ROLLER GROUP - FÖRDERROLLE - GRUPPO RULLINI

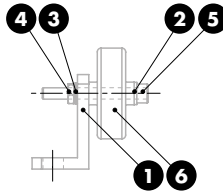
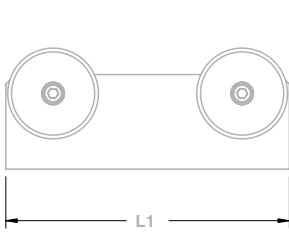

- Notes**
- 1 Material: St52
 - 2 3 Washer for M6
 - 4 Nut for M6
 - 5 M6x50 DIN 912
 - 6 025.90.55

STOCK WEB

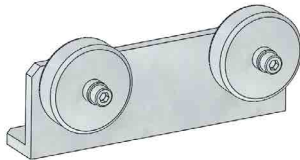

FORM A

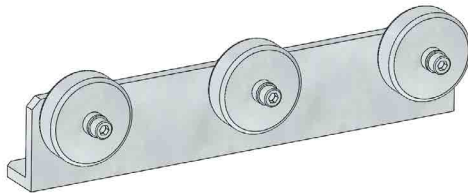

FORM B

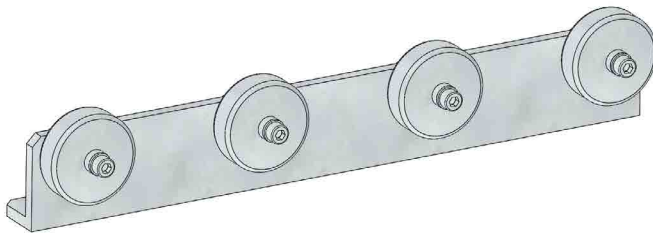

FORM C

	FCA CODE
	SP_R_250

FCA CODE	L1	FORM
SP_R_150	150	A
SP_R_250	250	B
SP_R_350	350	C

Standard FCA

ROLLER - ROLLE - ROTELLA

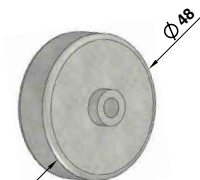

Notes

Material: Steel

STOCK



WEB



FCA CODE

ROT_048015

FCA CODE

ROT_048015

SPRING GROUP - FEDEREINHEIT - GRUPPO MOLLA

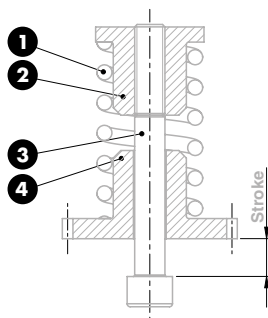
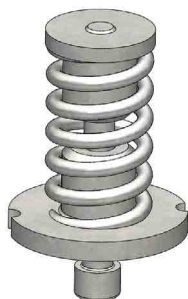

Notes

- 1 Spring
- 2 4 **Material:** CK45
- 3 M12x150 DIN 912

STOCK



WEB



FCA CODE

GR_MTR_C15

FCA CODE

GR_MTR_C15

Stroke

15

SPRING GROUP - FEDEREINHEIT - GRUPPO MOLLA

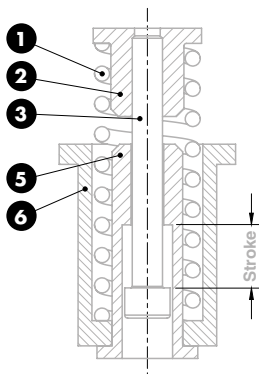
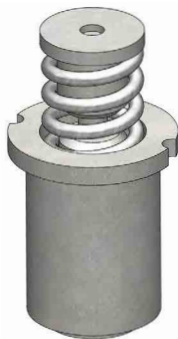

Notes

- 1 Spring
- 2 5 6 Material: CK45
- 3 M12x150 DIN 912



ORDER EXAMPLE	FCA CODE
	GR_MO_C50
FCA CODE	Stroke
GR_MO_C25	25
GR_MO_C50	50

Standard FCA

LIFTER STOP - ANSCHLAG HEBER - GRUPPO ARRESTO TRALICCIO

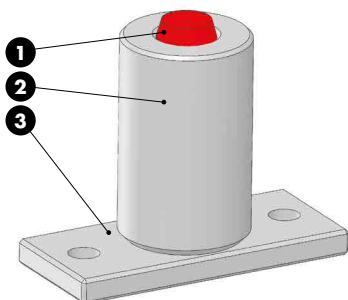

Notes

- 1 Material: Elastomer 90SH
- 2 Material: C40
- 3 Material: Fe320



ORDER EXAMPLE	FCA CODE
	GRA_TRA1
FCA CODE	
GRA_TRA1	

SPRING GROUP - FEDEREINHEIT - GRUPPO MOLLA

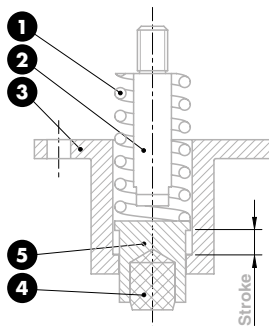

Notes

- 1 Spring
- 2 3 Material: 16MnCr5
- 4 Material: Urelast 90 SH
- 5 Material: 36CrNiMo4



ORDER EXAMPLE 	FCA CODE
	GR_RIM_TRA1
FCA CODE	Stroke
GR_RIM_TRA1	13

STRIPPER FOR BLANKING DIES
 ABSTREIFER FÜR PLATINENSCHNITTE
 ESTRATTORE PER STAMPI TRANCIASVILUPPO



Notes

Material: Elastomer 70SH



ORDER EXAMPLE 	FCA CODE
	ES_EL_027306
FCA CODE	
ES_EL_027306	

ROLLER STOCK LIFTER - FEDERENDE LAUFROLLE - RULLINO SOLLEVAMENTO NASTRO

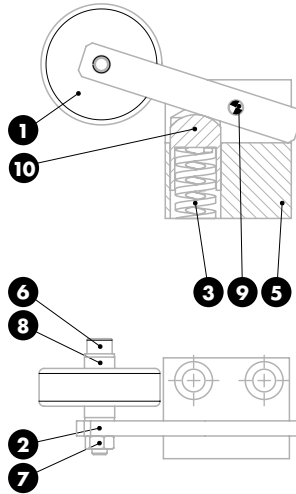
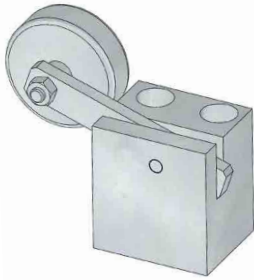

Notes

- 1 Material:** Steel
ROT_048015 - 025.90.55
- 2 5 Material:** St37
- 3** Spring - load = 2 kg
- 6** M6x40 DIN 912
- 7** M6 DIN 934
- 8** DIN 127
- 9** 6x30 DIN 6325
- 10 Material:** 16MnCr5



ORDER EXAMPLE	FCA CODE
	GRRU_SN_040080
FCA CODE	
GRRU_SN_040080	

Standard FCA

SPRING GROUP - FEDEREINHEIT - GRUPPO MOLLA

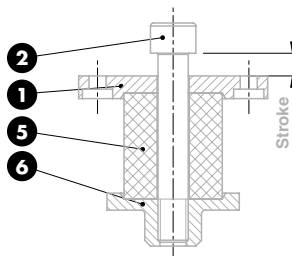
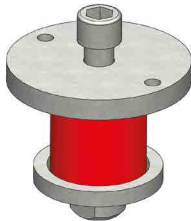

Notes

- 1 Material:** CK45
- 2** M16x100 DIN 912
- 5 Material:** Elastomer 92 SH
- 6 Material:** 36NiCrMo4



ORDER EXAMPLE	FCA CODE
	GR_MTR_C12
FCA CODE	Stroke
GR_MTR_C12	12

PAD RETAINER - ZUGBOLZENSATZ - GRUPPO DI ARRESTO

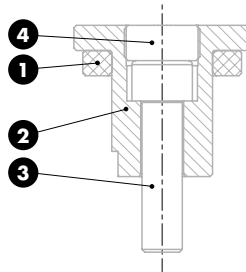
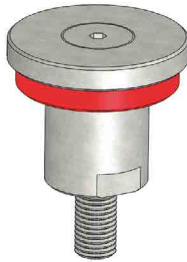

Notes

- 1 Material:** Elastomer 90SH
- 3** M16x60 DIN 912
- 4 Material:** CK45
- 2 Material:** 36CrNiMo4

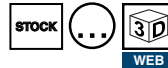

FCA CODE

GR_AR_070100

FCA CODE

GR_AR_070100

PAD RETAINER - ZUGBOLZENSATZ - GRUPPO DI ARRESTO

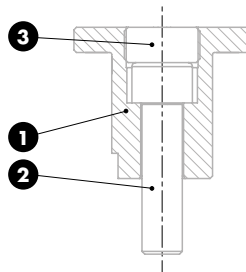

Notes

- 1 Material:** 36CrNiMo4
- 2** M16x60 DIN 912
- 3 Material:** CK45

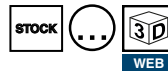

FCA CODE

GR_SI_070100

FCA CODE

GR_SI_070100

ROLLER - ROLLE - GRUPPO RULLO DI EVACUAZIONE

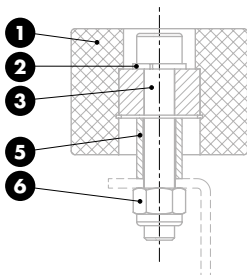
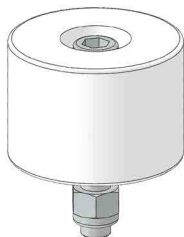

Notes

- 1** Material: Nylon
- 2** DIN 127
- 3** M12x70 DIN 912
- 5** Material: CK45
- 6** M12 DIN 6924



FCA CODE

GRRU_EV_070050

FCA CODE

GRRU_EV_070050

GUIDE POST GROUP - FUHRUNGSSÄULE MIT FÜHRUNGSLAGER - GRUPPO COLONNA

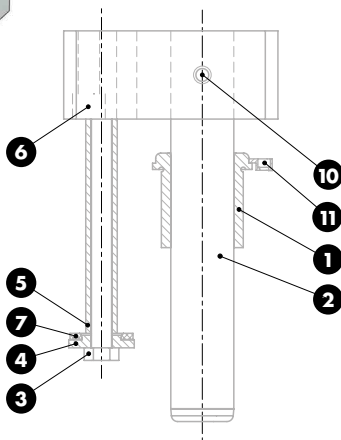
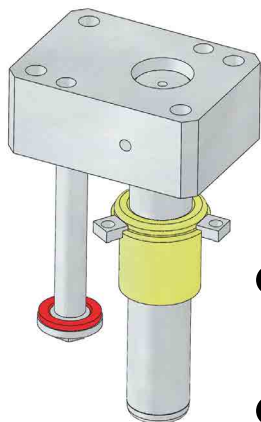

Notes

- 1** Material: Bronze - HB>190
- 2** Material: 16MnCr5 - HRC: 58÷60
- 3** **4** Material: CK45
- 5** Material: C12
- 6** Material: St52
- 7** Material: Elastomer 90 SH
- 10** M12x30 DIN 913
- 11** Material: St37



FCA CODE

GRC_AR_D50300

FCA CODE

GRC_AR_D50300

SPRING GROUP - FEDEREINHEIT - GRUPPO MOLLA

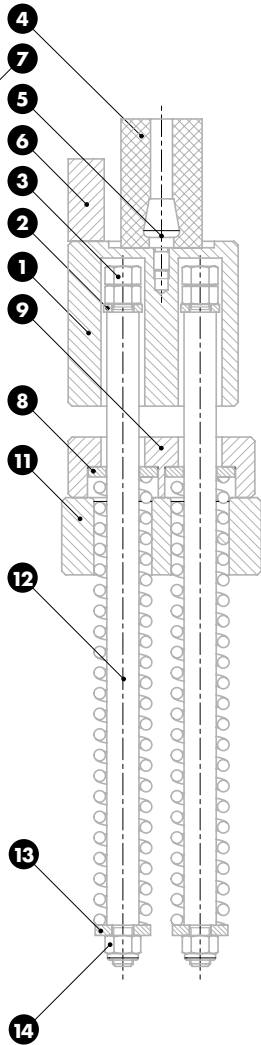
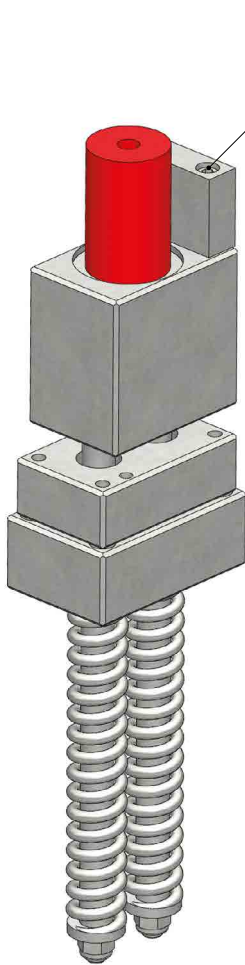

Notes

- 1 9 11 Material:** St37
- 2 8 13 Material:** CK45
- 3** M16 DIN 934
- 4 5** 095.90.20 - 095.90.25
- 6 12 Material:** 36NiCrMo4
- 7** M10x60 DIN912
- 14** M16 DIN 6924



Standard FCA

ORDER EXAMPLE	FCA CODE	
	GR_MTR_C120	
FCA CODE	Stroke	
GR_MTR_C120	120	

COMPENSATION BLOCK - ABSTANDSBLOCK - TASSELLO DI COMPENSAZIONE

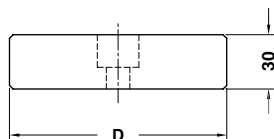

Notes

Material: 42CrMo4 - **HRC:** 46÷48

STOCK



WEB



FCA CODE
TC_100030

FCA CODE	COMMODITY CODE	D
TC_080030	19-235-0058	80
TC_100030	19-235-0057	100
TC_120030	19-235-0054	120

SPACER PLATE TOOTHED - DISTANZPLATTE GEZAHNT - TASSELLO DI COMPENSAZIONE

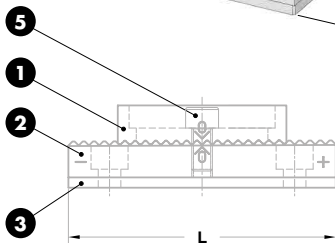
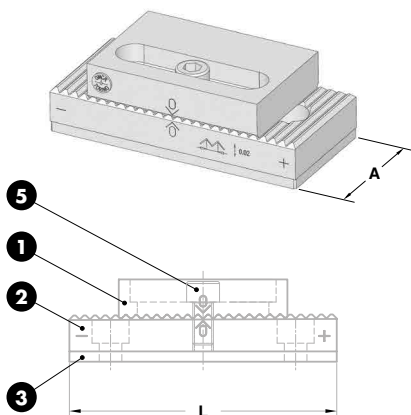

Notes

- ① ② **Material:** 90MnCrV8
HRC: 58÷60
- ③ **Material:** X155CrVMo12
- ⑤ DIN 912

STOCK



WEB



FCA CODE
TCRS_16080

FCA CODE	COMMODITY CODE	A	L
TCRS_13060	19-010-0123	60	130
TCRS_16080	19-010-0122	80	160

PRE-CENTERING PUNCH - STEMPELVORZENTRIERUNG - PRECENTRAGGIO PUNZONE

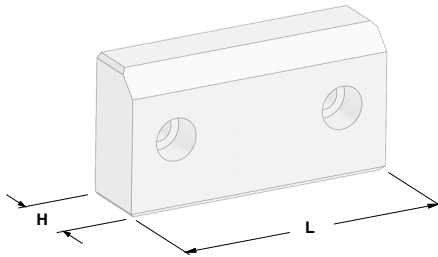

Notes		
Material: Ertalon		
STOCK	3D	WEB
ORDER EXAMPLE	FCA CODE	
	PPSP_90SH	
FCA CODE	L	H
PPSP_100SH	100	20
PPSP_90SH	115	31

LOWER AIR CUSHION PIN - UNTERLUFTBOLZEN - CANDELA INFERIORE

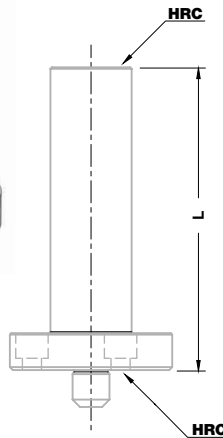
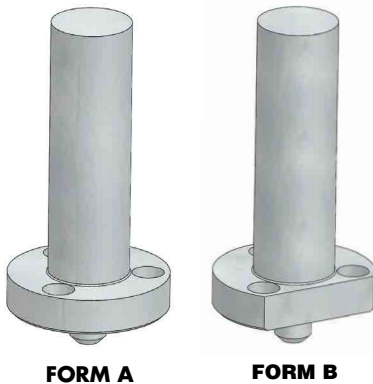

Notes	
Material: 42CrMo4 - HRC: 50÷52	
10	3D
	WEB

ORDER EXAMPLE 	FCA CODE
	CA_A_50

FCA CODE	COMMODITY CODE	L	FORM	FCA CODE	COMMODITY CODE	L	FORM
CA_A_25	19-235-0142	25	A	CA_B_25	19-235-0068	25	B
CA_A_50	19-235-0141	50	A	CA_B_50	19-235-0067	50	B
CA_A_75	19-235-0140	75	A	CA_B_75	19-235-0066	75	B
CA_A_100	19-235-0143	100	A	CA_B_100	19-235-0065	100	B
CA_A_125	19-235-0139	125	A	CA_B_125	19-235-0064	125	B
CA_A_150	19-235-0138	150	A	CA_B_150	19-235-0063	150	B
CA_A_175	19-235-0073	175	A	CA_B_175	19-235-0062	175	B
CA_A_200	19-235-0071	200	A	CA_B_200	19-235-0061	200	B
CA_A_225	19-235-0070	225	A	CA_B_225	19-235-0060	225	B
CA_A_250	19-235-0069	250	A	CA_B_250	19-235-0059	250	B

GAGE - EINWEISER - RIFERIMENTO

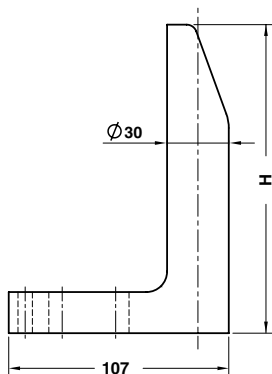

Notes

Material: CK60

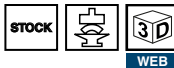

FCA CODE	COMMODITY CODE	H
RIF_L_065	19-010-1706	65
RIF_L_090	19-010-1709	90
RIF_L_120	19-010-1712	120
RIF_L_150	19-010-1715	150
RIF_L_180	19-010-1718	180
RIF_L_250	19-010-1725	250

GAGE HARDENED - EINWEISER GEHÄRTET - RIFERIMENTO INDURITO

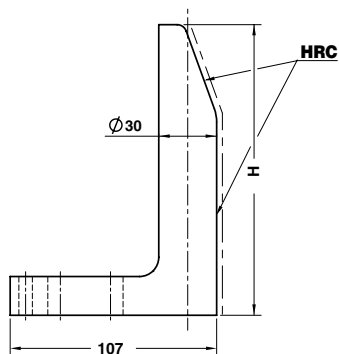
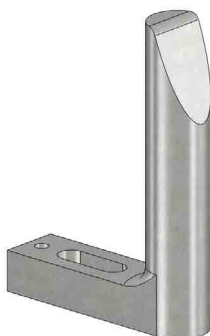

Notes

Material: CK60 - HRC: 56÷60

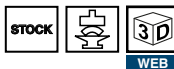

COMMODITY CODE	H
19-010-0208	65
19-010-0209	90
19-010-0210	120
19-010-0211	150
19-010-0212	180
19-010-0213	250

GAGE FOR SENSOR - EINWEISER FÜR TEILLAGEKONTROLLE - RIFERIMENTO PER SENSORE

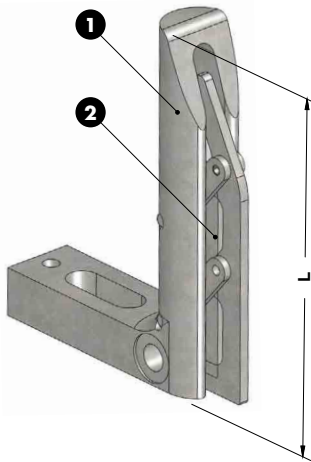

Notes

- ① **Material:** CK60
 ② **Material:** St37 - HRC: 58÷60

STOCK



WEB



FCA CODE
RIF_M12L150

FCA CODE	L
RIF_M12L120	120
RIF_M12L150	150
RIF_M12L180	180
RIF_M12L250	250

Standard FCA

AIR RELIEF TUBING - TUBE - TUBETTO SFOGO ARIA

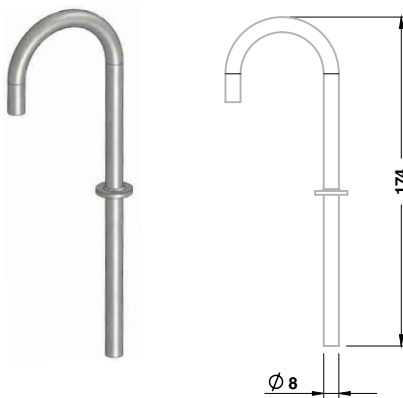

Notes

Material: Steel

STOCK



WEB



FCA CODE
TU_08174

FCA CODE
TU_08174

FLANGE LIFTER - ABSTREIFER - SFLANGIATORE

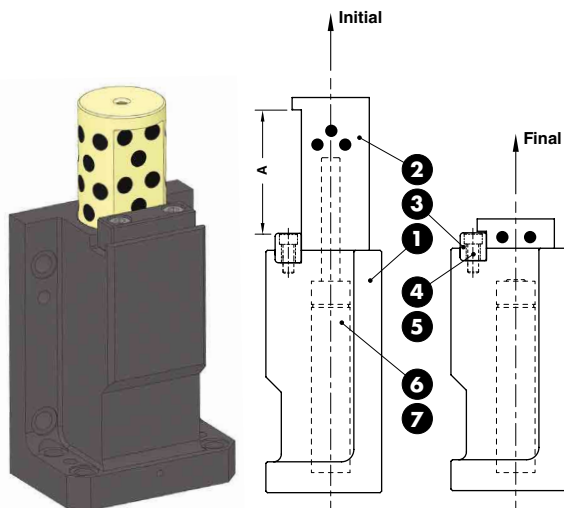

Notes

- 1 **Material:** EN-GJL300
- 2 **Material:** Bronze + Graphite - HB>190
- 3 **Material:** 36NiCrMo4
- 4 M8x30 DIN 912
- 5 Schnorr Ø8
- 6 Gas Spring
- 7 M6x12 DIN 7991

STOCK



WEB



FCA CODE
C16.30.50100

Supplier No.	A	Initial (daN)	Final (daN)
C16.30.50050	50	50	86
C16.30.50100	50	100	172
C16.30.50150	50	150	258
C16.30.50200	50	200	344
C16.30.80050	80	50	86
C16.30.80100	80	100	172
C16.30.80150	80	150	258
C16.30.80200	80	200	344

KEY - PASSFEDER - CHIAVETTA

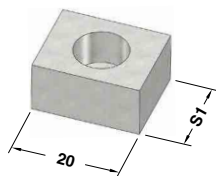

Notes

Material: CK45

STOCK



WEB



FCA CODE
CH_MA_101620

FCA CODE	S1
CH_MA_081220	12
CH_MA_101620	16

ROLLER CAM UNITS CRX - ROLLENSCHIEBER CRX - CAMMA A RULLO CRX

Without Positive Return - **OPTION X**

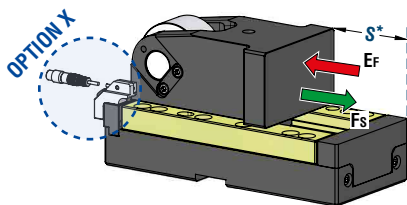

With Positive Return - **OPTION P**

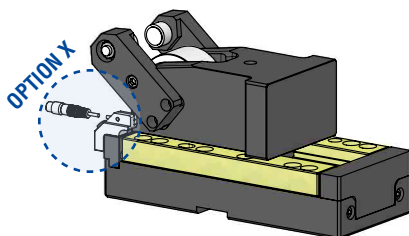

With Driver - **OPTION DRIVER**

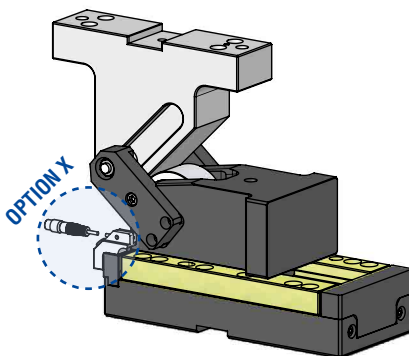

Notes

For technical info see pages 874-898



Back Position Check - **OPTION X**

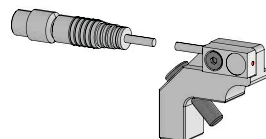

Montable on right or left side
auf rechte bzw. linke Seite montierbar
Montabile sul lato destro e sinistro

Standard FCA



FCA CODE
SEE ORDER CODE ON OMCR CAM UNITS PAGES

CRX TYPE	Work Angle β	Slider Width (mm)	Work Area W x H (mm)	Max Work Force 10° cycles (kN)	Extraction Force (kN)	OMCR cam units pages
				F _S	E _F	
CRX01	-15°÷50°	78	78x63	45	2,5÷3,4	874
CRX03	-15°÷50°	98	98x63	76	3,4÷3,6	880
CRX05	-15°÷50°	118	118x74	142	6,36÷6,46	886
CRX15	-15°÷50°	170	170x94	166	6,45÷6,61	892
CRX20	-15°÷50°	240	240x110	258	9,29÷9,38	898

AERIAL CAM UNIT CHD
OBEN HÄNGENDER SCHIEBER CHD
UNITÀ A CAMME SOSPESA CHD

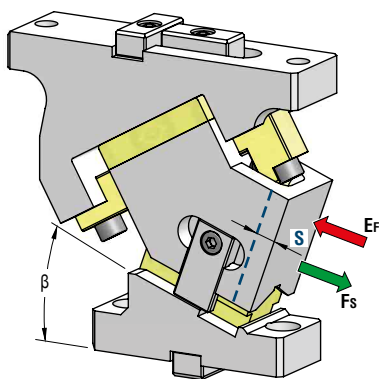

Notes

For technical info see pages 634÷666

STOCK

3D

WEB

WEB



FCA CODE

SEE ORDER CODE ON OMCR CAM UNITS PAGES

CHD TYPE	Work Angle β	Slider Width (mm)	Closed Cam Height (mm)	Work Area W x H (mm)	Max Work Force with shoulder 10 ⁶ cycles (kN)	Extraction Force (kN)		OMCR cam units pages
						E _f		
						F _s	Spring	
CHD050	0°÷65° (5° steps)	50	180	50x65	60	1,14÷1,31	1,44÷1,72	634
CHD065	0°÷65° (5° steps)	65	180	65x65	60	1,14÷1,31	1,44÷1,72	638
CHD080	0°÷65° (5° steps)	80	275	80x88	149	1,13÷1,37	1,50÷1,85	642
CHD100	0°÷65° (5° steps)	100	275	100x88	149	1,13÷1,37	1,50÷1,85	646
CHD150	0°÷65° (5° steps)	150	355	150x120	391	2,29	7,15	650
CHD180	0°÷65° (5° steps)	180	355	180x120	396	2,29	7,15	654
CHD200	0°÷65° (5° steps)	200	355	200x120	396	2,29	7,15	658
CHD250	0°÷65° (5° steps)	250	355	250x160	645	4,58	14,30	662
CHD300	0°÷65° (5° steps)	300	355	300x160	645	4,58	14,30	666

AERIAL CAM UNIT CHV
OBEN HÄNGENDER SCHIEBER CHV
UNITÀ A CAMME SOSPESA CHV

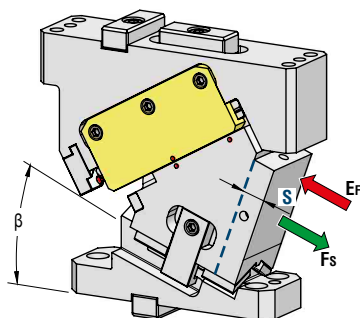

Notes

For technical info see pages 712÷760

STOCK

3D

WEB

WEB



FCA CODE

SEE ORDER CODE ON OMCR CAM UNITS PAGES

CHV TYPE	Work Angle β	Slider Width (mm)	Closed Cam Height (mm)	Work Area W x H (mm)	Max Work Force with shoulder 10 ⁶ cycles (kN)	Extraction Force (kN)	OMCR cam units pages
					F _s	E _r	
CHV050	0°÷75° (5° steps)	50	175÷195	60x100	92÷110	4,5÷6,1	712
CHV060	0°÷75° (5° steps)	60	210	60x100	136÷143	5,1÷6,2	716
CHV085	0°÷75° (5° steps)	85	225	85x120	229÷293	7,10÷12	720
CHV110	0°÷75° (5° steps)	110	275	110x160	357÷407	6,2÷16,8	724
CHV150	0°÷75° (5° steps)	150	300	150x160	421÷584	17,3÷20,8	728
CHV180	0°÷75° (5° steps)	180	300	180x160	474÷598	17,1÷20,5	732
CHV220	0°÷75° (5° steps)	220	300	220x160	635÷732	16,6÷46,2	736
CHV260	0°÷75° (5° steps)	260	300	260x160	536÷767	16,6÷46,2	740
CHV330	0°÷75° (5° steps)	330	375	330x180	1005÷1020	46,5÷94,9	744
CHV400	0°÷75° (5° steps)	400	375	400x180	1052÷1055	48÷87,1	748
CHV500	0°÷75° (5° steps)	500	375	500x180	1155	64,5÷87,0	752
CHV600	0°÷75° (5° steps)	600	400	600x200	1202	84,2÷98,2	758

AERIAL CAM UNIT CLB
OBEN HÄNGENDER SCHIEBER CLB
UNITÀ A CAMME SOSPESA CLB

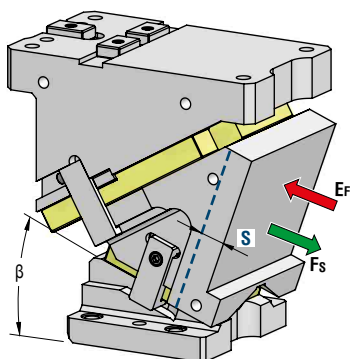

Notes

For technical info see pages 804+820

STOCK

3D

WEB

WEB



FCA CODE

SEE ORDER CODE ON OMCR CAM UNITS PAGES

CLB TYPE	Work Angle β	Slider Width (mm)	Closed Cam Height (mm)	Work Area W x H (mm)	Max Work Force with shoulder 10 ⁶ cycles (kN)	Extraction Force (kN)		OMCR cam units pages
						E _f		
						Spring	Gas Spring	
CLB200	0°÷60° (5° steps)	200	350	200x180	302	2,12÷2,73	8,88÷11,42	804
CLB300	0°÷60° (5° steps)	300	350	300x180	411	4,25÷5,46	17,76÷22,83	808
CLB400	0°÷60° (5° steps)	400	350	400x180	526	4,25÷5,46	17,76÷22,83	812
CLB500	0°÷60° (5° steps)	500	350	500x180	743	6,37÷8,19	26,64÷34,25	816
CLB600	0°÷60° (5° steps)	600	350	600x180	865	8,50÷10,92	35,52÷45,67	820

DISTANCE PLATE FOR WEAR PLATE HÖHENAUSGLEICH FÜR GLEITPLATTE DISTANZIALE PER PIASTRA

* Provided 0,5 mm plus for adjustment
wird mit 0,5 mm Aufmaß geliefert, zur Anpassung am Werkzeug
Fornita maggiorata di 0,5 mm per adattamento su stampo

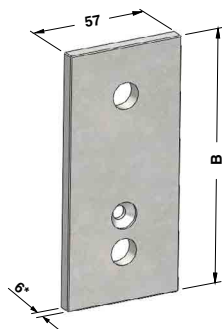

FORM A

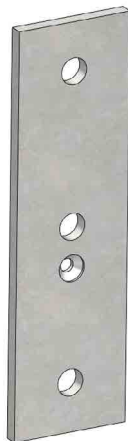

FORM B

Notes

Material: St37

STOCK



WEB

ORDER
EXAMPLE

FCA CODE

PSP2S_057006158

FCA CODE	COMMODITY CODE	B	FORM
PSP2S_057006123	19-005-0161	123	A
PSP2S_057006158	19-005-0162	158	A
PSP2S_057006198	19-005-0163	198	B
PSP2S_057006248	19-005-0164	248	B
PSP2S_057006318	19-005-0165	318	B

Standard FCA

WEAR PLATE SELF-LUBRICATING GLEITPLATTE BRONZE MIT FESTSCHMIERSTOFF PIASTRA GUIDA AUTOLUBRIFICANTE

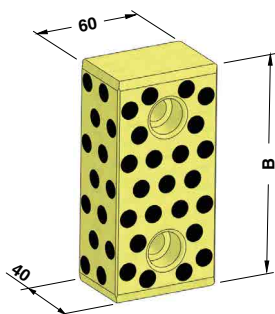

FORM A



FORM B

Notes

Material: Bronze + Graphite - HB > 190

STOCK



WEB

ORDER
EXAMPLE

FCA CODE

P2S_060040160

FCA CODE	COMMODITY CODE	B	FORM
P2S_060040125	19-205-0179	125	A
P2S_060040160	19-205-0178	160	A
P2S_060040200	19-205-0177	200	B

WEAR PLATE STEEL
GLEITPLATTE STAHL
PIASTRA GUIDA IN ACCIAIO

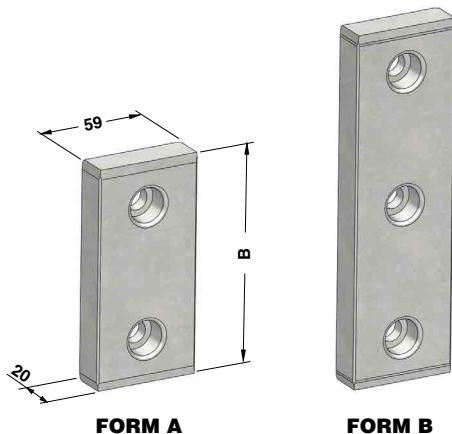

FORM A

FORM B

Notes

Material: 16MnCr5 - **HRC:** 58÷62

STOCK



WEB

ORDER EXAMPLE	FCA CODE		
	PA2S_059020160		
FCA CODE	COMMODITY CODE	B	FORM
PA2S_059020125	19-205-0176	125	A
PA2S_059020160	19-205-0180	160	A
PA2S_059020200	19-205-0181	200	B
PA2S_059020250	19-205-0182	250	B
PA2S_059020320	19-205-0183	320	B

WEAR PLATE STEEL - DECKLEISTE STAHL - PIASTRA GUIDA IN ACCIAIO



FORM A

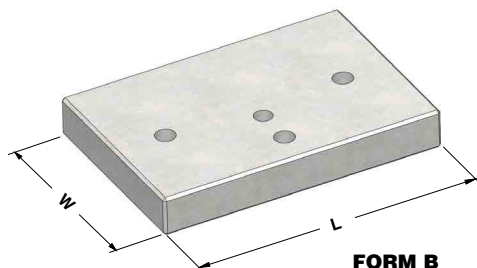

FORM B

Notes

Material: 42CrMo4 - **HRC:** 58÷62

STOCK



WEB

ORDER EXAMPLE	FCA CODE		
	LA_130200_S		
FCA CODE	W	L	FORM
LA_130160_S	130	160	A
LA_130200_S	130	200	A
LA_170250_S	170	250	B
LA_170320_S	170	320	B

WEAR PLATE STEEL - DECKLEISTE STAHL - PIASTRA GUIDA IN ACCIAIO



FORM A

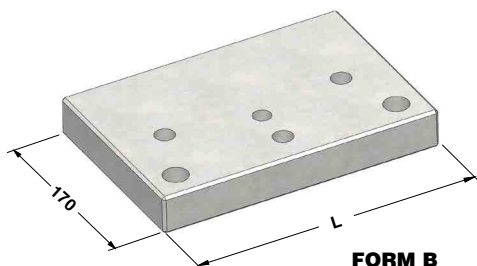

FORM B

Notes

Material: 42CrMo4 - HRC: 58÷62

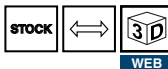

ORDER EXAMPLE	FCA CODE
	LA_170200_C

FCA CODE	L	FORM
LA_170160_C	160	A
LA_170200_C	200	A
LA_170250_C	250	B
LA_170320_C	320	B

Standard FCA

"V" DRIVER STEEL VDI 3357
 PRISMENFÜHRUNG STAHL VDI 3357
 GUIDA A "V" IN ACCIAIO VDI 3357

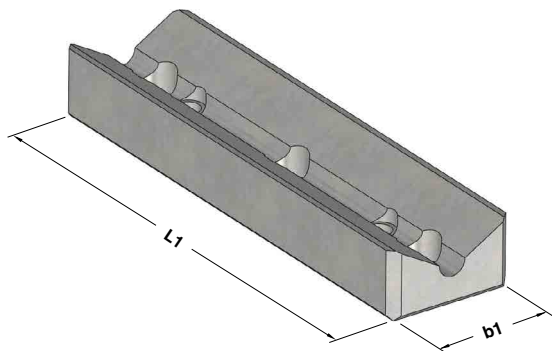

Notes

Material: CK45 - HRC: 58÷60



ORDER EXAMPLE	FCA CODE
	G_V_200065_F

FCA CODE	COMMODITY CODE	b1	L1
G_V_150065_F	19-205-0213	65	150
G_V_200065_F	19-205-0214	65	200
G_V_250065_F	19-205-0215	65	250
G_V_300065_F	19-205-0216	65	300
G_V_150125_F	19-205-0217	125	150
G_V_200125_F	19-205-0218	125	200
G_V_250125_F	19-205-0219	125	250
G_V_300125_F	19-205-0221	125	300

"V" DRIVER SELF-LUBRICATING VDI 3357
PRISMENFÜHRUNG BRONZE MIT FESTSCHMIERSTOFF VDI 3357
GUIDA A "V" AUTOLUBRIFICANTE VDI 3357

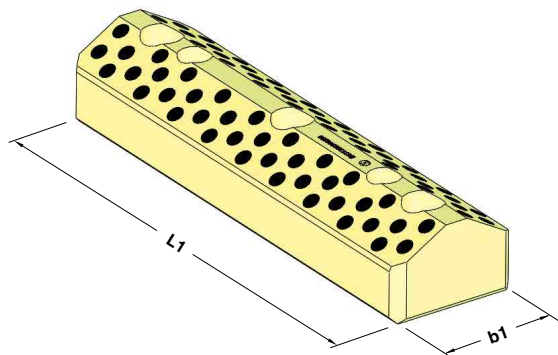

Notes

Material: Bronze + Graphite - HB > 190

STOCK



WEB



FCA CODE	
G_V_200065_M	

FCA CODE	COMMODITY CODE	b1	L1
G_V_150065_M	19-205-0205	65	150
G_V_200065_M	19-205-0206	65	200
G_V_250065_M	19-205-0207	65	250
G_V_300065_M	19-205-0208	65	300
G_V_150125_M	19-205-0209	125	150
G_V_200125_M	19-205-0210	125	200
G_V_250125_M	19-205-0211	125	250
G_V_300125_M	19-205-0212	125	300

DISTANCE PLATE FOR "V" DRIVER
HÖHENAUSGLEICH FÜR PRISMENFUHRUNG
DISTANZIALE PER GUIDA A "V"

* Provided 0,5 mm plus for adjustment
 wird mit 0,5 mm Aufmaß geliefert, zur Anpassung am Werkzeug
 Fornita maggiorata di 0,5 mm per adattamento su stampo

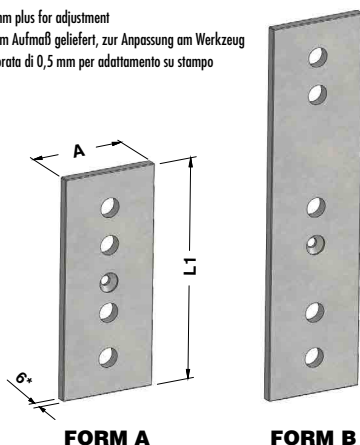

Notes

Material: St37

STOCK



WEB



FCA CODE	
SP_V_06200065	

FCA CODE	A	L1	FORM
SP_V_06150065	63	148	A
SP_V_06200065	63	198	A
SP_V_06250065	63	248	A
SP_V_06300065	63	298	A
SP_V_06150125	123	148	B
SP_V_06200125	123	198	B
SP_V_06250125	123	248	B
SP_V_06300125	123	298	B

ANGULAR GUIDE - WINKELLEISTE - GUIDA ANGOLARE

Notes

Material: Bronze + Graphite - HB > 190

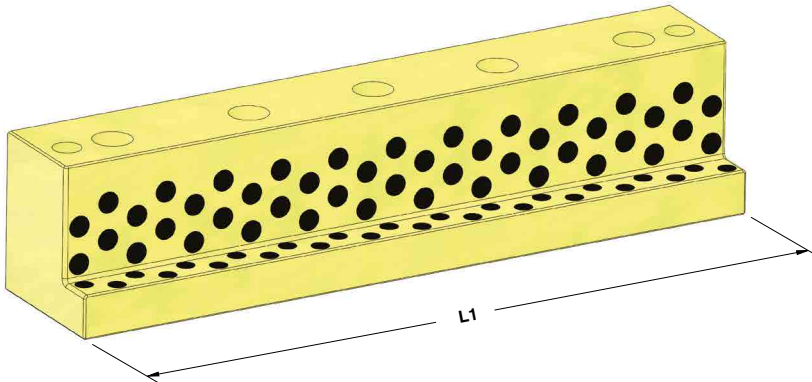
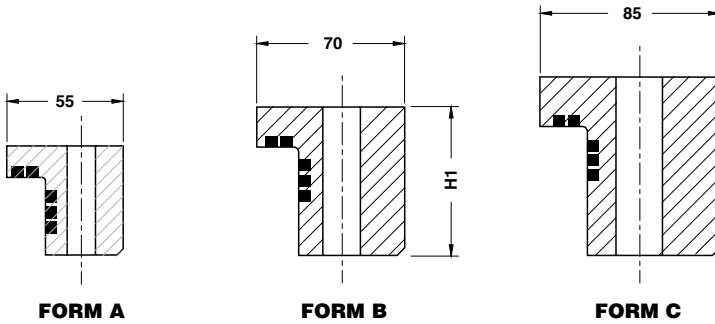
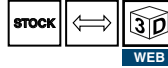

Standard FCA

ORDER EXAMPLE	FCA CODE
	G_L_055055160

FCA CODE	COMMODITY CODE	L1	H1	FORM	FCA CODE	COMMODITY CODE	L1	H1	FORM
G_L_055055100	19-205-0165	100	55,5	A	G_L_070075400	19-205-0170	400	75,5	B
G_L_055055160	19-205-0166	160	55,5	A	G_L_085090160	19-205-0171	160	90,5	C
G_L_070075160	19-205-0167	160	75,5	B	G_L_085090200	19-205-0172	200	90,5	C
G_L_070075200	19-205-0168	200	75,5	B	G_L_085090250	19-205-0173	250	90,5	C
G_L_070075250	19-205-0169	250	75,5	B	G_L_085090400	19-205-0174	400	90,5	C

FORK PAWL - BEFESTIGUNGSPLATTE - FORCELLA NOTTOLINO

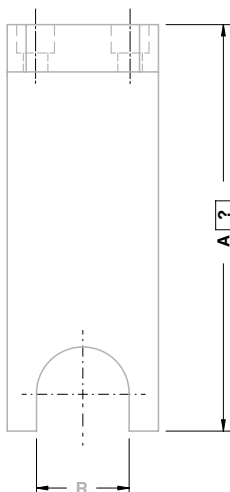
 $150 \leq A \leq 220$

Notes

Material: Si37



ORDER EXAMPLE	FCA CODE	A=?
	FOR_49	160
FCA CODE		R
FOR_39		39
FOR_49		49

POSITIVE RETURN PLATE - ZWANGSRÜCKHOLER - GANCIO DI SICUREZZA

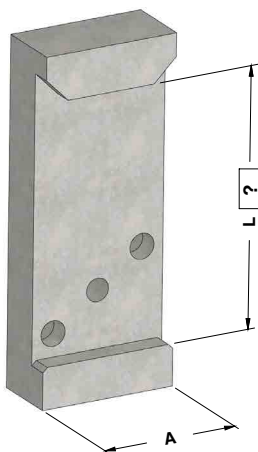

Notes

Material: CK45 - HRC: 52÷54



ORDER EXAMPLE	FCA CODE	L=80
	GA_60	80
FCA CODE		A
GA_35		35
GA_60		60

STOP BLOCK - ANSCHLAG - ARRESTO

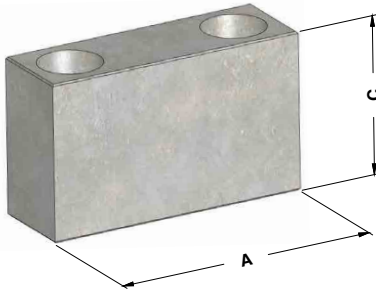

Notes

Material: CK45

ORDER EXAMPLE	FCA CODE	
	ARR_752545	
FCA CODE	A	C
ARR_502545	50	45
ARR_502565	50	65
ARR_752545	75	45
ARR_752565	75	65

Standard FCA

SLIDE STOP BLOCK - SCHIEBERANSCHLAG - ARRESTO SLITTA

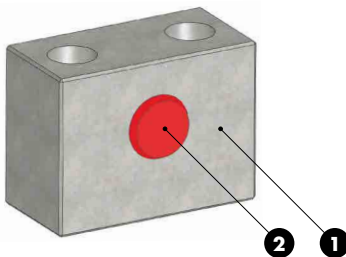

Notes

- 1 **Material:** CK45
- 2 **Material:** Urelast 92SH
PU_EL_24 - 080.90.90



ORDER EXAMPLE	FCA CODE
	ARR_AMM_D24
FCA CODE	
	ARR_AMM_D24

RETAINER BOLT - ZUGBOLZENSATZ - GRUPPO TIRANTE

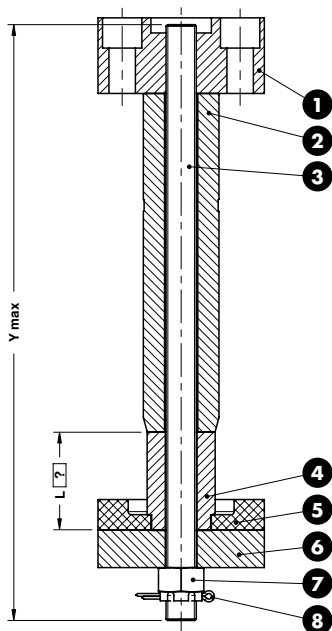

Notes

- 1 19-010-5551
- 2 19-245-7907/7908/7909/7910
- 3 19-010-6535/6537/6539/6542
- 4 19-010-5552
- 5 19-010-5553
- 6 19-010-5554
- 7 M20 Hexagon slotted nut DIN 935
- 8 Split Pin. DIN EN ISO 1234



ORDER EXAMPLE	COMMODITY CODE	L=50
	19-010-7507	L50

COMMODITY CODE	Y max	Max load (kg)
19-010-7505	350	450
19-010-7507	370	450
19-010-7509	395	450
19-010-7512	420	450

RETAINER BOLT - ZUGBOLZENSATZ - GRUPPO TIRANTE



- Notes**
- 1 19-010-5651
 - 2 19-245-8008/8009/8010/8011
 - 3 19-010-6638/6641/6643/6646
 - 4 19-010-5652
 - 5 19-010-5553
 - 6 19-010-5554
 - 7 M24 Hexagon slotted nut DIN 935
 - 8 Split Pin. DIN EN ISO 1234



Standard FCA

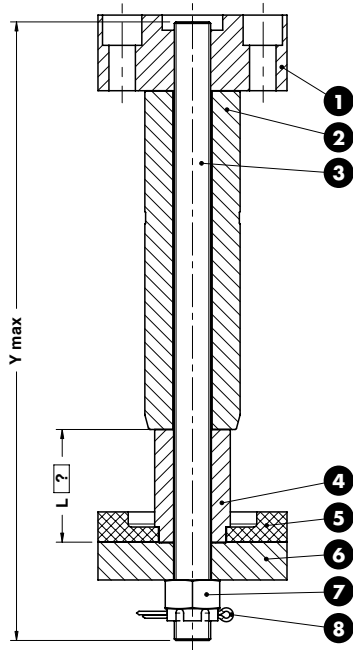

ORDER EXAMPLE	COMMODITY CODE	L=70
	19-010-7607	L70

COMMODITY CODE	Y max	Max load (kg)
19-010-7605	380	750
19-010-7607	405	750
19-010-7610	430	750
19-010-7613	455	750

RETAINER BOLT - ZUGBOLZENSATZ - GRUPPO TIRANTE

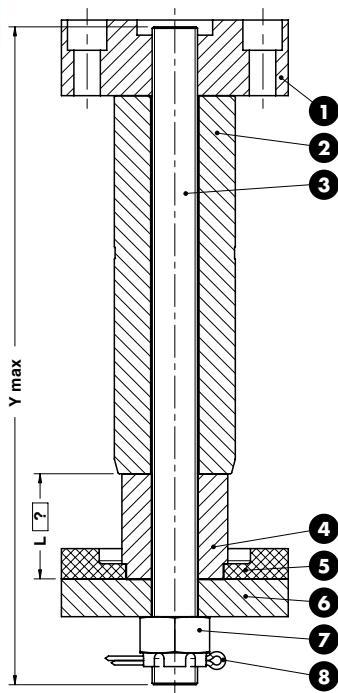

Notes

- 1 19-010-5751
- 2 19-245-8210/8211/8212/8214
- 3 19-010-6744/6747/6750/6754
- 4 19-010-5752
- 5 19-010-5753
- 6 19-010-5754
- 7 M30 Hexagon slotted nut DIN 935
- 8 Split Pin. DIN EN ISO 1234



WEB

ORDER EXAMPLE	COMMODITY CODE	L=65
	19-010-7710	L65

COMMODITY CODE	Y max	Max load (kg)
19-010-7707	440	1250
19-010-7710	475	1250
19-010-7714	500	1250
19-010-7718	540	1250

RETAINER BOLT - ZUGBOLZENSATZ - GRUPPO TIRANTE

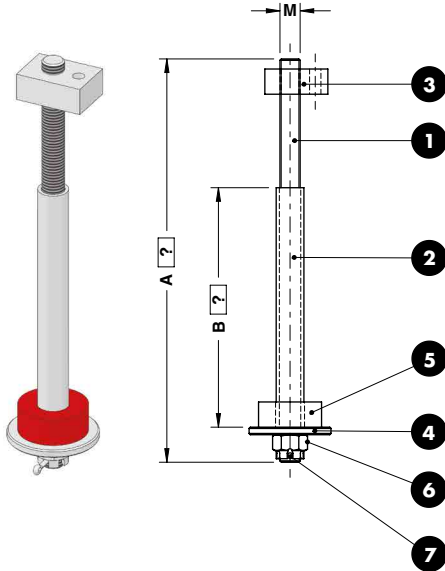

Respect the max. load
 Maximale Nutzlast beachten
 Rispettare il carico max.

Notes

- 1 **Material:** Thread rod cl 8.8
- 2 3 **Material:** St37
- 4 **Material:** CK45
- 5 **Material:** Elastomer 92SH
- 6 **Material:** DIN 935 cl. 8.8
- 7 **Material:** DIN 94



Application example

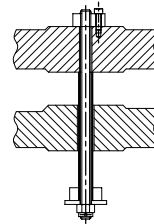

Standard FCA

	FCA CODE	A=100	B=60
	GRTI_M16	A100	B60

FCA CODE	M	Max load (kg)
GRTI_M16AB	M16	250

RETAINER BOLT - ZUGBOLZENSATZ - GRUPPO TIRANTE

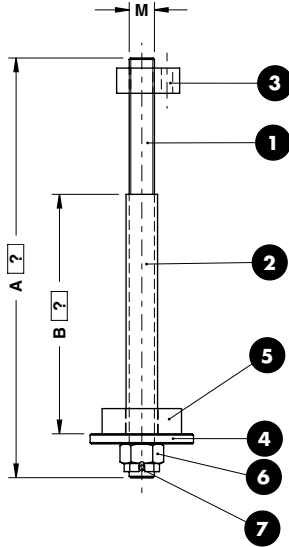
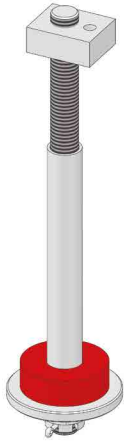

Respect the max. load
 Maximale Nutzlast beachten
 Rispettare il carico max.

Notes

- 1 **Material:** Thread rod cl 8.8
- 2 3 **Material:** St37
- 4 **Material:** CK45
- 5 Elastomer 92SH
- 6 DIN 935 cl. 8.8
- 7 DIN 94



Application example

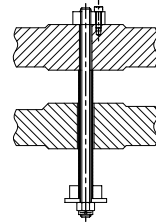

ORDER EXAMPLE	FCA CODE	A=100	B=60
	GRTI_M20	A100	B60

FCA CODE	M	Max load (kg)
GRTI_M20AB	M20	450

RETAINER BOLT - ZUGBOLZENSATZ - GRUPPO TIRANTE

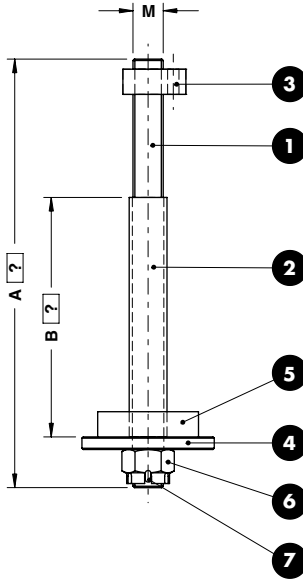

Respect the max. load
 Maximale Nutzlast beachten
 Rispettare il carico max.

Notes

- 1 **Material:** Thread rod cl 8.8
- 2 3 **Material:** St37
- 4 **Material:** CK45
- 5 **Material:** Elastomer 92SH
- 6 **Material:** DIN 935 cl. 8.8
- 7 **Material:** DIN 94



Application example

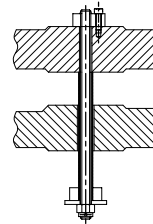

Standard FCA

ORDER EXAMPLE	FCA CODE	A=100	B=60
	GRTI_M24	A100	B60

FCA CODE	M	Max load (kg)
GRTI_M24AB	M24	750

RETAINER BOLT - ZUGBOLZENSATZ - GRUPPO TIRANTE

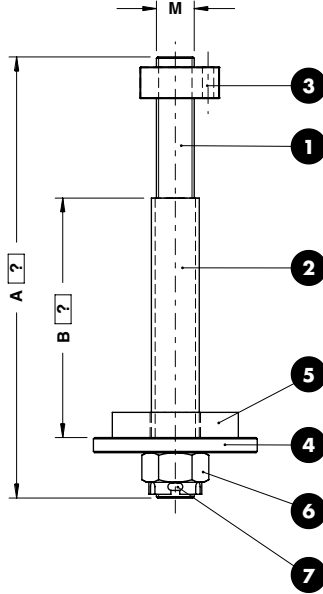

Respect the max. load
 Maximale Nutzlast beachten
 Rispettare il carico max.

Notes

- 1 **Material:** Thread rod cl 8.8
- 2 3 **Material:** St37
- 4 **Material:** CK45
- 5 Elastomer 92SH
- 6 DIN 935 cl. 8.8
- 7 DIN 94



Application example

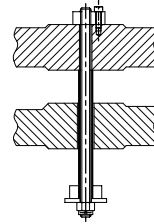

FCA CODE	A=100	B=60
GRTI_M30	A100	B60

FCA CODE	M	Max load (kg)
GRTI_M30AB	M30	1250

SHOCK ABSORBER - HALTEELEMENT - AMMORTIZZATORE

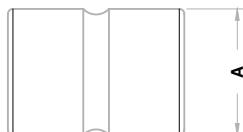

Notes

Material: Elastomer 92 SH



	FCA CODE	
	AMM_06380	
FCA CODE	COMMODITY CODE	A
AMM_05070	19-001-0072	50
AMM_06380	19-001-0073	63

Standard FCA

GUIDE POST DIN 9833 - FÜHRUNGSSÄULE DIN 9833 - COLONNA GUIDA DIN 9833



Notes

Material: Steel - HRC 60÷62



WEB

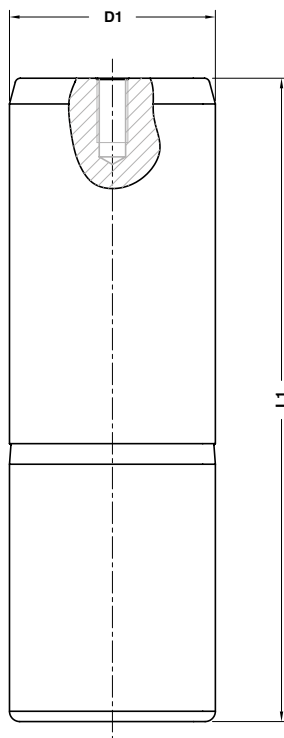

FCA CODE

COL_080315_V

FCA CODE	COMMODITY CODE	D1	L1	FCA CODE	COMMODITY CODE	D1	L1
COL_080250_V	19-245-7210	80	250	COL_100400_V	19-245-7416	100	400
COL_080280_V	19-245-7211	80	280	COL_125355_V	-	125	355
COL_080315_V	19-245-7212	80	315	COL_125400_V	19-245-7816	125	400
COL_080355_V	19-245-7214	80	355	COL_125450_V	19-245-7818	125	450
COL_100315_V	19-245-7412	100	315	COL_125500_V	19-245-7820	125	500
COL_100355_V	19-245-7414	100	355	COL_125550_V	19-245-7822	125	550

GUIDE POST DIN 9833 - FÜHRUNGSSÄULE DIN 9833 - COLONNA GUIDA DIN 9833

Notes

Material: Steel - HRC 60÷62

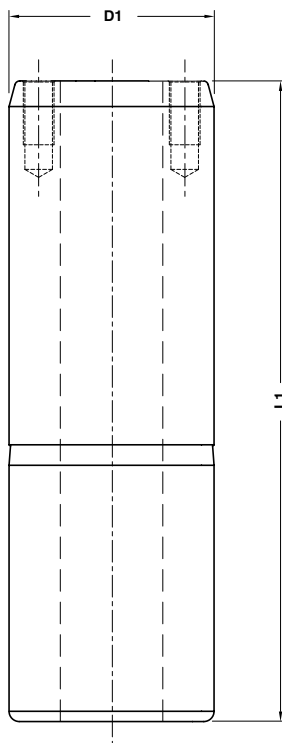

Standard FCA

ORDER EXAMPLE	FCA CODE
	COLH_080280_V

FCA CODE	COMMODITY CODE	D1	L1	FCA CODE	COMMODITY CODE	D1	L1
COLH_080250_V	19-245-0034	80	250	COLH_100400_V	19-245-0027	100	400
COLH_080280_V	19-245-0033	80	280	COLH_125355_V	19-245-0039	125	355
COLH_080315_V	19-245-0032	80	315	COLH_125400_V	19-245-0038	125	400
COLH_080355_V	19-245-0031	80	355	COLH_125450_V	19-245-0037	125	450
COLH_100315_V	19-245-0029	100	315	COLH_125500_V	19-245-0036	125	500
COLH_100355_V	19-245-0028	100	355	COLH_125550_V	19-245-0035	125	550

GUIDE POST - FÜHRUNGSSÄULE - COLONNA GUIDA

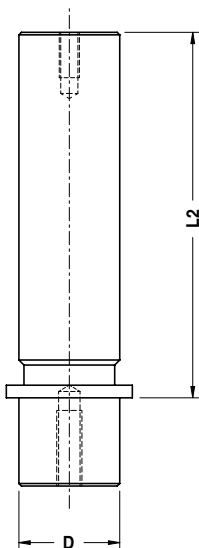

Notes

Material: Steel - HRC 60÷62



Supplied with retainers and screws.
Befestigungsklammern und Schrauben im Lieferumfang enthalten.
Fornite con staffette di fissaggio e viti.



FCA CODE
COL_SL_25110

FCA CODE	COMMODITY CODE	D	L2	FCA CODE	COMMODITY CODE	D	L2
COL_SL_25100	19-250-0053	25	100	COL_SL_40180	19-250-0077	40	180
COL_SL_25110	19-250-0054	25	110	COL_SL_40200	19-250-0076	40	200
COL_SL_25120	19-250-0055	25	120	COL_SL_40220	19-250-0075	40	220
COL_SL_25130	19-250-0056	25	130	COL_SL_40240	19-250-0074	40	240
COL_SL_25140	19-250-0057	25	140	COL_SL_50110	19-250-0073	50	110
COL_SL_25160	19-250-0058	25	160	COL_SL_50120	19-250-0072	50	120
COL_SL_25170	19-250-0059	25	170	COL_SL_50130	19-250-0071	50	130
COL_SL_25180	19-250-0060	25	180	COL_SL_50140	19-250-0070	50	140
COL_SL_25200	19-250-0061	25	200	COL_SL_50160	19-250-0069	50	160
COL_SL_32100	19-250-0062	32	100	COL_SL_50170	19-250-0068	50	170
COL_SL_32110	19-250-0063	32	110	COL_SL_50180	19-250-0092	50	180
COL_SL_32120	19-250-0064	32	120	COL_SL_50200	19-250-0091	50	200
COL_SL_32130	19-250-0065	32	130	COL_SL_50220	19-250-0090	50	220
COL_SL_32140	19-250-0066	32	140	COL_SL_50240	19-250-0089	50	240
COL_SL_32160	19-250-0067	32	160	COL_SL_63130	19-250-0100	63	130
COL_SL_32170	19-250-0004	32	170	COL_SL_63140	19-250-0088	63	140
COL_SL_32180	19-250-0080	32	180	COL_SL_63160	19-250-0099	63	160
COL_SL_32200	19-250-0081	32	200	COL_SL_63170	19-250-0098	63	170
COL_SL_32220	19-250-0082	32	220	COL_SL_63180	19-250-0097	63	180
COL_SL_32240	19-250-0083	32	240	COL_SL_63200	19-250-0096	63	200
COL_SL_40110	19-250-0084	40	110	COL_SL_63220	19-250-0095	63	220
COL_SL_40120	19-250-0085	40	120	COL_SL_63240	19-250-0101	63	240
COL_SL_40130	19-250-0086	40	130	COL_SL_80200	19-250-0094	80	200
COL_SL_40140	19-250-0079	40	140	COL_SL_80220	19-250-0093	80	220
COL_SL_40160	19-250-0087	40	160	COL_SL_80240	19-250-0102	80	240
COL_SL_40170	19-250-0078	40	170				

GUIDE POST - FÜHRUNGSSÄULE - COLONNA GUIDA

Notes

Material: Steel - HRC 60÷62

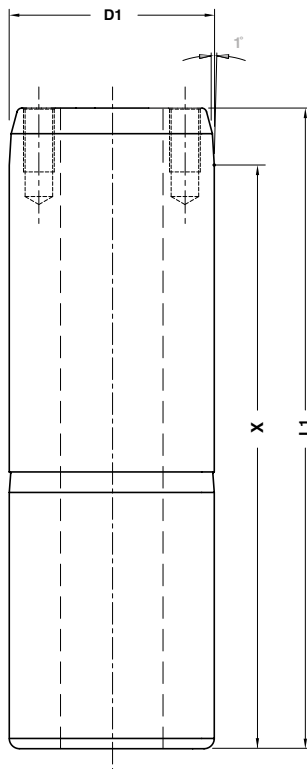
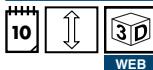

Standard FCA

	FCA CODE		
	COLH100355_T		
FCA CODE	D1	L1	X
COLH100315_T	100	315	250
COLH100355_T	100	355	290

BUSH SELF-LUBRICATING DIN 9834
FÜHRUNGSBUCHSE DIN 9834
BOCCOLA AUTOLUBRIFICANTE DIN 9834

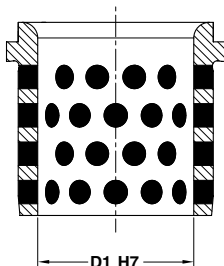

Notes

Material: Bronze + Graphite
HB > 190

STOCK



WEB

ORDER
EXAMPLE

FCA CODE

BOC_032050_V

FCA CODE	COMMODITY CODE	D1
BOC_025040_V	19-029-0023	25
BOC_032050_V	19-029-0024	32
BOC_040063_V	19-029-0025	40
BOC_050071_V	19-029-0026	50
BOC_063080_V	19-029-0029	63
BOC_080100_V	19-029-0027	80
BOC_100125_V	19-029-0028	100
BOC_125160_V	19-029-0030	125

TOE CLAMP - HALTESTÜCK - RITEGNO PER BOCCOLA

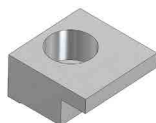

Notes

Material: CK45

Application example

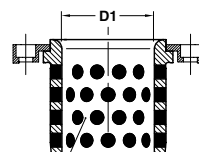

065.090.85

STOCK



WEB

ORDER
EXAMPLE

FCA CODE

RIT_323216

FCA CODE	COMMODITY CODE	D1
RIT_202010	19-010-0106	25-50
RIT_323216	19-010-0105	63-160

BUSH SELF LUBRICATING - FÜHRUNGSBUCHSE - BOCCOLA AUTOLUBRIFICANTE

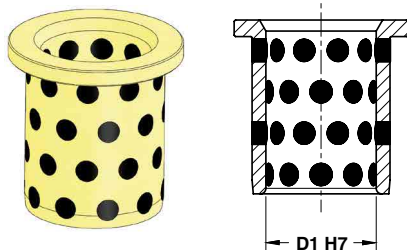

Notes

Material: Bronze + Graphite
HB >190

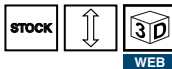

ORDER EXAMPLE	FCA CODE
	BO_PR_50_H7

FCA CODE	D1
BO_PR_25_H7	25
BO_PR_32_H7	32
BO_PR_40_H7	40
BO_PR_50_H7	50
BO_PR_63_H7	63
BO_PR_80_H7	80
BO_PR_100_H7	100
BO_PR_125_H7	125

Standard FCA

TOE CLAMP - HALTESTÜCK - RITEGNO PER BOCCOLA

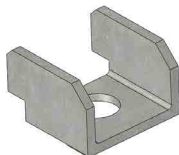

Notes

Material: CK45



ORDER EXAMPLE	COMMODITY CODE
	19-029-0100

COMMODITY CODE
19-029-0100

WEAR PLATE SELF-LUBRICATING VDI 3357
GLEITPLATTE BRONZE MIT FESTSCHMIERSTOFF VDI 3357
PIASTRA GUIDA AUTOLUBRIFICANTE VDI 3357

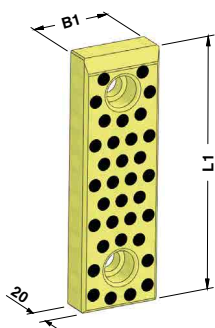

FORM A

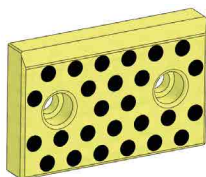

FORM B

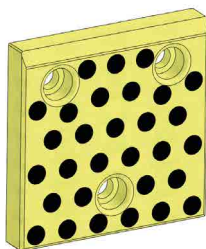

FORM C

Notes
Material: Bronze + Graphite - HB > 190
 Only for replacement
 Nur für Reparatur
 Solo per riparazione

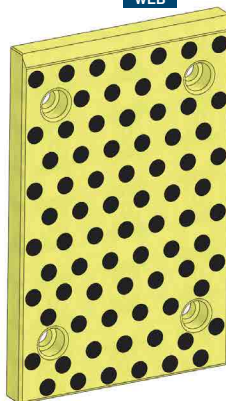
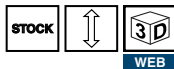

FORM D

ORDER EXAMPLE	FCA CODE
	PBR_05020100

FCA CODE	COMMODITY CODE	B1	L1	FORM	FCA CODE	COMMODITY CODE	B1	L1	FORM
PBR_05020080	19-290-0069	50	80	A	PBR_10020315	-	100	315	A
PBR_05020100	19-290-3204	50	100	A	PBR_12520050	19-290-0071	125	50	B
PBR_05020125	19-290-3205	50	125	A	PBR_12520080	19-290-3503	125	80	B
PBR_05020160	19-290-3206	50	160	A	PBR_12520100	19-290-3504	125	100	C
PBR_05020200	19-290-3208	50	200	A	PBR_12520125	19-290-3505	125	125	C
PBR_08020050	19-290-0067	80	50	B	PBR_12520160	19-290-3506	125	160	C
PBR_08020080	19-290-0066	80	80	A	PBR_12520200	19-290-3508	125	200	C
PBR_08020100	19-290-3304	80	100	A	PBR_12520250	-	125	250	C
PBR_08020125	19-290-3305	80	125	A	PBR_12520315	-	125	315	C
PBR_08020160	19-290-3306	80	160	A	PBR_16020050	19-290-0075	160	50	C
PBR_08020200	19-290-3308	80	200	A	PBR_16020080	19-290-0073	160	80	C
PBR_10020050	19-290-3402	100	50	B	PBR_16020100	19-290-3604	160	100	C
PBR_10020080	19-290-3403	100	80	B	PBR_16020125	19-290-3605	160	125	C
PBR_10020100	19-290-3404	100	100	A	PBR_16020160	19-290-3606	160	160	C
PBR_10020125	19-290-3405	100	125	A	PBR_16020200	19-290-3608	160	200	C
PBR_10020160	19-290-3406	100	160	A	PBR_16020250	-	160	250	D
PBR_10020200	19-290-3408	100	200	A	PBR_16020315	-	160	315	D
PBR_10020250	-	100	250	A					

WEAR PLATE STEEL VDI 3357
GLEITPLATTE STAHL VDI 3357
PIASTRA GUIDA IN ACCIAIO VDI 3357

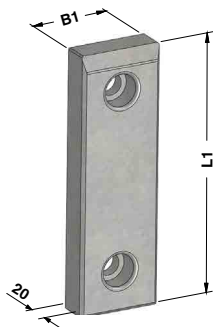

FORM A

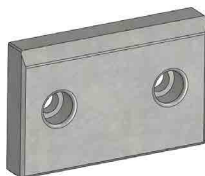

FORM B

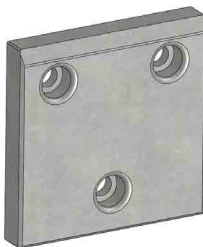

FORM C



FORM D

Notes

Material: 16MnCr5 - **HRC:** 58÷62

STOCK WEB

	FCA CODE
	PAC_05020100

FCA CODE	COMMODITY CODE	B1	L1	FORM	FCA CODE	COMMODITY CODE	B1	L1	FORM
PAC_05020080	19-290-0070	50	80	A	PAC_10020315	-	100	315	A
PAC_05020100	19-290-4204	50	100	A	PAC_12520050	19-290-0072	125	50	B
PAC_05020125	19-290-4205	50	125	A	PAC_12520080	19-290-4503	125	80	B
PAC_05020160	19-290-4206	50	160	A	PAC_12520100	19-290-4504	125	100	C
PAC_05020200	19-290-4208	50	200	A	PAC_12520125	19-290-4505	125	125	C
PAC_08020050	19-290-0068	80	50	B	PAC_12520160	19-290-4506	125	160	C
PAC_08020080	19-290-0065	80	80	A	PAC_12520200	19-290-4508	125	200	C
PAC_08020100	19-290-4304	80	100	A	PAC_12520250	-	125	250	C
PAC_08020125	19-290-4305	80	125	A	PAC_12520315	-	125	315	C
PAC_08020160	19-290-4306	80	160	A	PAC_16020050	19-290-0076	160	50	C
PAC_08020200	19-290-4308	80	200	A	PAC_16020080	19-290-0074	160	80	C
PAC_10020050	19-290-4402	100	50	B	PAC_16020100	19-290-4604	160	100	C
PAC_10020080	19-290-4403	100	80	B	PAC_16020125	19-290-4605	160	125	C
PAC_10020100	19-290-4404	100	100	A	PAC_16020160	19-290-4606	160	160	C
PAC_10020125	19-290-4405	100	125	A	PAC_16020200	19-290-4608	160	200	C
PAC_10020160	19-290-4406	100	160	A	PAC_16020250	-	160	250	D
PAC_10020200	19-290-4408	100	200	A	PAC_16020315	-	160	315	D
PAC_10020250	-	100	250	A					

Standard FCA

**DISTANCE PLATE FOR WEAR PLATE
HÖHENAUSGLEICH FÜR GLEITPLATTE
DISTANZIALE PER PIASTRA**

* Provided 0,5 mm plus for adjustment
wird mit 0,5 mm Aufmaß geliefert, zur Anpassung am Werkzeug
Fornita maggiorata di 0,5 mm per adattamento su stampo

Notes
Material: S37

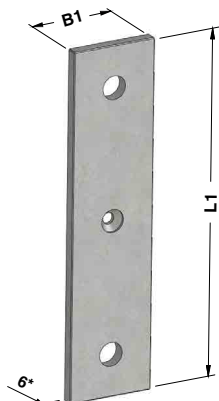

FORM A

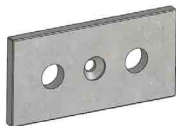

FORM B



FORM C



FORM D

ORDER EXAMPLE	FCA CODE
	PSP_08006050

FCA CODE	B1	L1	FORM	FCA CODE	B1	L1	FORM	FCA CODE	B1	L1	FORM
PSP_05006200	48	198	A	PSP_10006160	98	158	A	PSP_12506315	123	313	C
PSP_08006050	78	48	B	PSP_10006200	98	198	A	PSP_16006050	158	48	B
PSP_08006080	78	78	A	PSP_10006250	98	248	A	PSP_16006100	158	98	C
PSP_08006100	78	98	A	PSP_10006315	98	313	A	PSP_16006125	158	123	C
PSP_08006125	78	123	A	PSP_12506050	123	48	B	PSP_16006160	158	158	C
PSP_08006160	78	158	A	PSP_12506100	123	98	C	PSP_16006200	158	198	C
PSP_08006200	78	198	A	PSP_12506125	123	123	C	PSP_16006250	158	248	D
PSP_10006050	98	48	B	PSP_12506160	123	158	C	PSP_16006315	158	313	D
PSP_10006100	98	98	A	PSP_12506200	123	198	C				
PSP_10006125	98	123	A	PSP_12506250	123	248	C				

PAD RETAINER PIN - STECKBOLZEN - PERNO DI ARRESTO

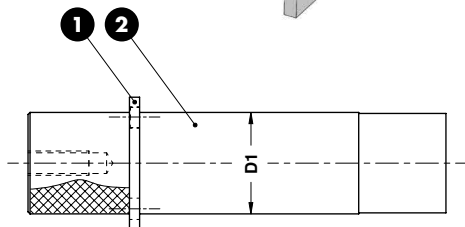
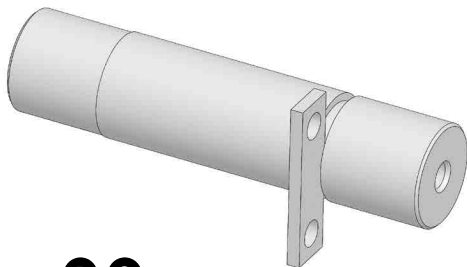

Notes

- 1 **Material:** St37
- 2 **Material:** 36CrNiMo4

Screws not included



FCA CODE

PRN_050206

FCA CODE	COMMODITY CODE	D1
PRN_040172	19-010-0098	40
PRN_050206	19-010-0097	50
-	19-010-0101	63

Standard FCA

LOCATING PIN - ZENTRIERBOLZEN - CENTRAGGIO



Notes

Material: 16MnCr5 - **HRC:** 58÷60

FCA CODE

PDC_04055

FCA CODE	COMMODITY CODE
PDC_04055	19-010-0104

BALANCE BLOCK - DISTANZSTÜCK - DISTANZIALE

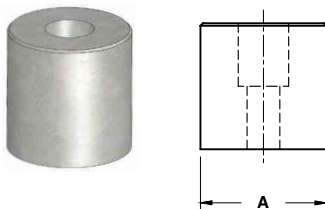

Notes

Material: CK45



ORDER EXAMPLE	FCA CODE
	DST_090050

FCA CODE	COMMODITY CODE	A
DST_050050	19-010-0102	50
DST_090050	19-010-0103	90

GUIDE PIN RETAINER PLATE - SICHERUNGSPLATTE - RITEGNO PER COLONNA

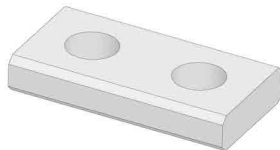

FORM A

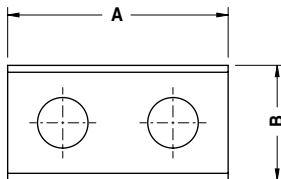

Notes

Material: CK45



ORDER EXAMPLE	FCA CODE
	19-010-0205

FCA CODE	A	B	FORM
19-010-0204	40	20	A
19-010-0205	48	25	A
19-010-0206	60	34	A
19-010-0251	80	57	B

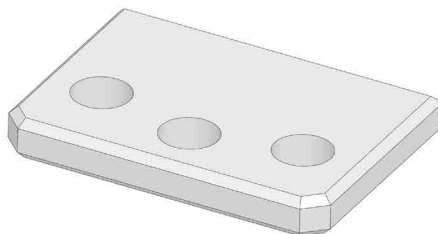

FORM B

SPRING PLUNGER - FEDERNE DRUCKSTÜCKE - ESPULSORE A MOLLA

Notes

Material: Steel



Spring plungers can be fitted/removed by means of the slot or internal hexagon.

Montage/demontage mit Innensechskant und Schlitz möglich.

Il montaggio/smontaggio avviene sia tramite l'esagono incassato, che tramite l'intaglio frontale.

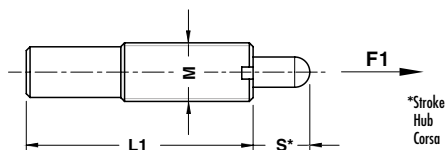

FCA CODE

ESP_H_M1615

FCA CODE	COMMODITY CODE	M	L1	S	F1 (N/mm ²)	F2 (N/mm ²)
ESP_H_M1210	42-497-0104	M12	45	10	7	40
ESP_H_M1615	42-497-0220	M16	60	15	15	80
ESP_H_M1630	42-497-0093	M16	125	30	20	80

PRESSURE PLATE - DRUCKPLATTE - PIASTRA DI REAZIONE

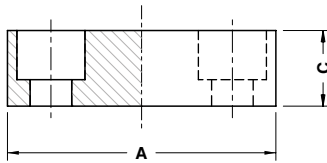
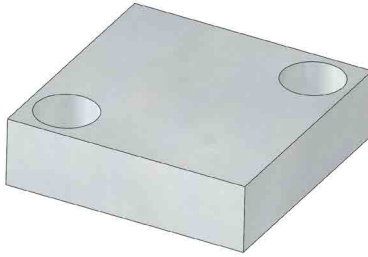

Notes

Material: 90MnCrV8 - HRC: 50÷52



ORDER EXAMPLE		FCA CODE	
		RE_565620_Q	
FCA CODE	COMMODITY CODE	A	C
RE_404015_Q	19-010-0151	40	15
RE_565620_Q	19-010-0154	56	20
RE_717120_Q	19-010-0153	71	20
RE_909020_Q	19-010-0152	90	20
RE_14014020_Q	19-010-0150	140	20

PRESSURE PLATE - DRUCKPLATTE - PIASTRA DI REAZIONE

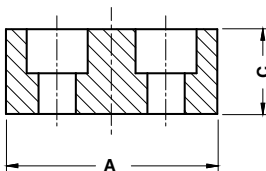
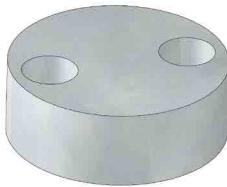

Notes

Material: 90MnCrV8 - HRC: 50÷52



ORDER EXAMPLE		FCA CODE	
		RE_70SP20_C	
FCA CODE	COMMODITY CODE	A	C
RE_50SP15_C	19-010-0155	50	15
RE_70SP20_C	19-010-0149	70	20
RE_94SP20_C	19-010-0148	94	20

PRESSURE PLATE - DRUCKPLATTE - PIASTRA DI REAZIONE

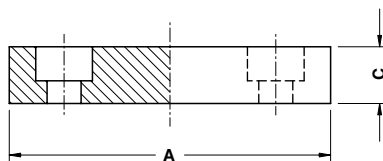
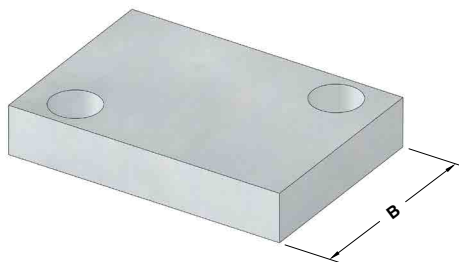

Notes

Material: 90MnCrV8 - **HRC:** 50÷52

STOCK



WEB



FCA CODE

RE_553012_R

FCA CODE	COMMODITY CODE	A	B	C
RE_502512_R	19-010-0147	50	25	12
RE_503012_R	19-010-0144	50	30	12
RE_703515_R	19-010-0146	70	35	15
RE_755015_R	19-010-0143	75	50	15
RE_856015_R	19-010-0142	85	60	15
RE_1008020_R	19-010-0141	100	80	20
RE_11010020_R	19-010-0139	110	100	20

Standard FCA

CLAMP - BEFESTIGUNGSELEMENT - MORSETTO

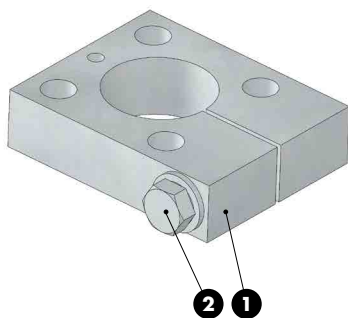

Notes

1 **Material:** CK45

2 M12x70 DIN 931

STOCK



WEB



FCA CODE

MOR_025080100

FCA CODE

MOR_025080100

SLEEVE - FÜHRUNGSEINHEIT - CANOTTO GUIDA

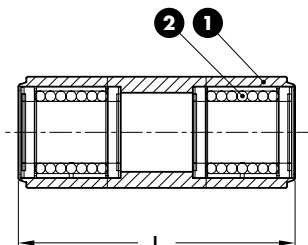

Notes

- 1** Material: CK45
- 2** Material: STAR 0658-225-40

STOCK



WEB

ORDER
EXAMPLE

FCA CODE

BOC_025200_4B

FCA CODE

L

BOC_025112_4A

230

BOC_025200_4B

315

ELASTOMER CAP - ELASTOMERDRUCKSTÜK - PUNTALINO ELASTICO

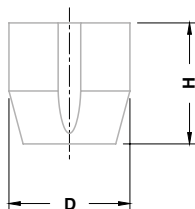
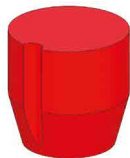

Notes

Material: Urelast 92 SH



ORDER EXAMPLE	FCA CODE
	PU_EL_10

FCA CODE	D	H	F max (N)	FCA CODE	D	H	F max (N)
PU_EL_06	6	9,5	100	PU_EL_30	30	35	3000
PU_EL_10	10	15,5	450	PU_EL_32	32	32	12000
PU_EL_16	16	25	1500	PU_EL_39,5	39,5	40	25000
PU_EL_24	24	25	3000				

085.90.135

COUPLING PLATE - BEFESTIGUNGSPLATTE - STAFFA DI REAZIONE

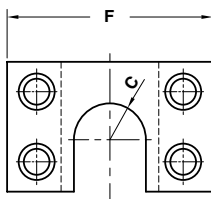
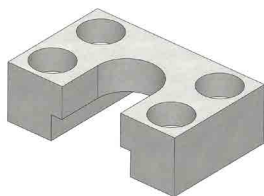

Notes

Material: CK45



ORDER EXAMPLE	FCA CODE
	FO_NO_4740

FCA CODE	COMMODITY CODE	F	C
FO_NO_3530	19-010-2360	80	14
FO_NO_4740	19-010-2365	100	20
FO_NO_5750	19-010-2370	120	25
N/A	19-010-2375	150	33

COUPLING NUT - KUPPLUNGSMUTTER - AGGANCIO STAFFA

Notes

Material: CK45

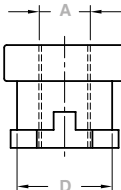

ORDER EXAMPLE	FCA CODE
	NO_3530M12

FCA CODE	COMMODITY CODE	D	A
NO_3530M10	39-295-0032	25	M10 x 1,25
NO_3530M12	39-295-0031	25	M12 x 1,25
NO_4740M16	39-295-0029	37	M16 x 1,5
NO_4740M20	39-811-0667	37	M20 x 1,5
NO_5750M27	39-811-0416	47	M27 x 2
NO_5750M36	39-811-0455	47	M36 x 2
N/A	39-295-0033	59	M42 x 2

THREADED STEEL INSERT - GEWINDEINSATZ AUS STAHL - INSERTO FILETTATO IN ACCIAIO

Notes

Material: 42CrMo4

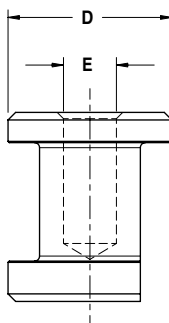
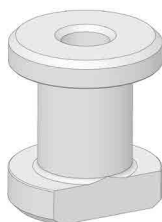

ORDER EXAMPLE	COMMODITY CODE
	19-235-0148

COMMODITY CODE	Max load 1 point (kg)	Max load 2÷4 point (kg)	D	E	COMMODITY CODE	Max load 1 point (kg)	Max load 2÷4 point (kg)	D	E
19-235-0149	2800	5600	65	M22 x 2,5	19-235-0146	6500	13000	107	M36 x 4,0
19-235-0148	3000	6000	65	M24 x 3,0	19-235-0145	7200	14400	107	M42 x 4,5
19-235-0147	5000	10000	85	M30 x 3,5					

ELASTOMER SPRING - ELASTOMERFEDER - MOLLA IN ELASTOMERO

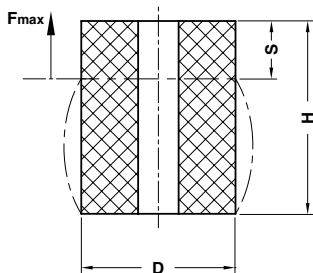

Notes

Material: Elastomer 92SH



S = max. 30% H



ORDER EXAMPLE	FCA CODE
	MOL_080080

FCA CODE	D	H	S	Fmax (N)	FCA CODE	D	H	S	Fmax (N)	FCA CODE	D	H	S	Fmax (N)
MOL_063100	63	100	30	2600	MOL_100080	100	80	24	5900	MOL_125125	125	125	37,5	9900
MOL_080080	80	80	24	4300	MOL_100100	100	100	30	5900	MOL_125160	125	160	48	9900
MOL_080100	80	100	30	4300	MOL_100125	100	125	37,5	5900					
MOL_080125	80	125	37,5	4300	MOL_125100	125	100	30	9900					

Standard FCA

ELASTOMER SPRING PIN - AUFNAHMEBOLZEN - PERNO PER MOLLE IN ELASTOMERO

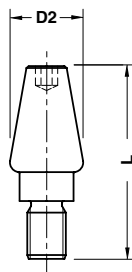

STOCK

Notes



Material: CK45

WEB

Application example

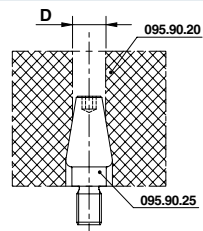

ORDER EXAMPLE	FCA CODE
	PRN_MO_M16

FCA CODE	D	D2	L
PRN_MO_M12	63÷80	28	56
PRN_MO_M16	100	32	74
PRN_MO_M20	125	38	100

LIFTING PIN - TRAGBOLZEN MIT FALLRINGSICHERUNG - PERNO DI SOLLEVAMENTO

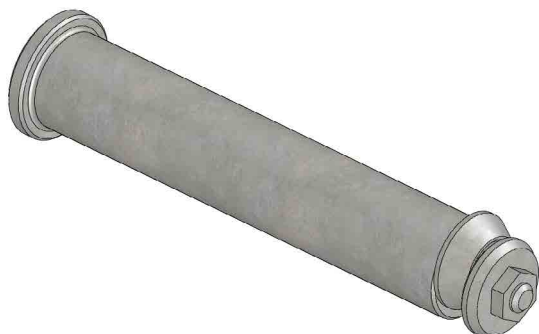

Respect the max load
Maximale Nutzlast beachten
Rispettare il carico Max

WARNING - ACHTUNG - ATTENZIONE:

For safety reason, please consider always that the weight of the die has to be supported by just 2 lifting pins.

Aus Sicherheitsgründen stets berücksichtigen, dass zwei Tragbolzen das gesamte Werkzeuggewicht tragen müssen.

Per ragioni di sicurezza, considerare sempre che il peso dello stampo deve essere sopportato da 2 soli perni.

Notes

Material: 42CrMo4 + QT

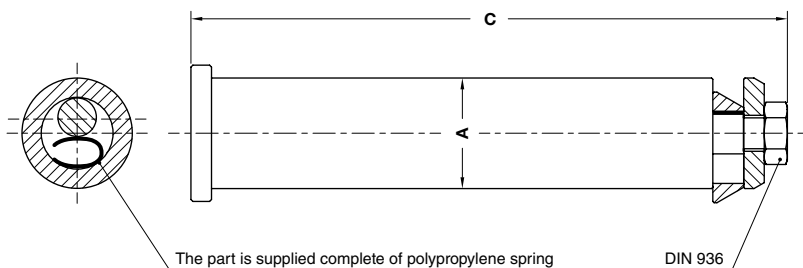

FCA CODE

SOL_KG7000_HL

FCA CODE	COMMODITY CODE	Max load (kg)	Max die weight (kg)	C	A
SOL_KG4000_HL	-	4000	8000	178,5	29
SOL_KG7000_HL	-	7000	14000	200,5	33

LIFTING PIN - TRAGBOLZEN MIT FALLRINGSICHERUNG - PERNO DI SOLLEVAMENTO



Respect the max load
Maximale Nutzlast beachten
Rispettare il carico Max

WARNING - ACHTUNG - ATTENZIONE:

For safety reason, please consider always that the weight of the die has to be supported by just 2 lifting pins.

Aus Sicherheitsgründen stets berücksichtigen, dass zwei Tragbolzen das gesamte Werkzeuggewicht tragen müssen.

Per ragioni di sicurezza, considerare sempre che il peso dello stampo deve essere sopportato da 2 soli perni.

Notes

Material: 42CrMo4 + QT

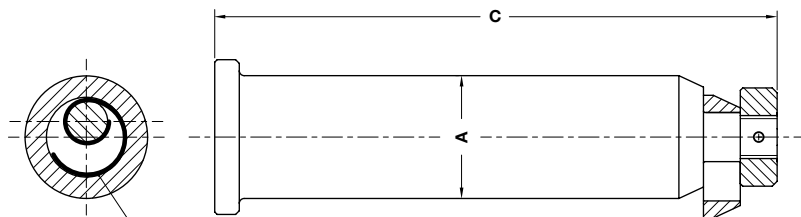

The part is supplied complete of steel spring



COMMODOTY CODE

19-255-0252

FCA CODE	COMMODITY CODE	Max load (kg)	Max die weight (kg)	C	A
-	19-255-0200	10000	20000	230	50
-	19-255-0252	20000	40000	320	63
-	19-255-0320	40000	80000	370	80

LIFTING PIN - TRAGBOLZEN MIT FALLRINGSICHERUNG - PERNO DI SOLLEVAMENTO

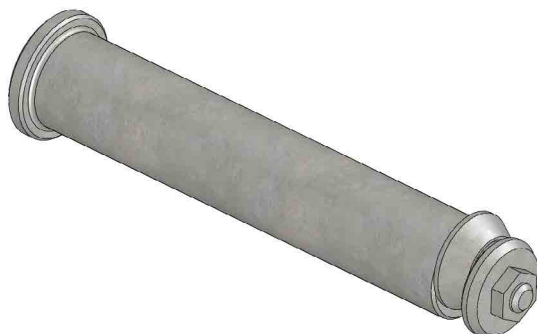

Respect the max load
Maximale Nutzlast beachten
Rispettare il carico Max

WARNING - ACHTUNG - ATTENZIONE:

For safety reason, please consider always that the weight of the die has to be supported by just 2 lifting pins.

Aus Sicherheitsgründen stets berücksichtigen, dass zwei Tragbolzen das gesamte Werkzeuggewicht tragen müssen.

Per ragioni di sicurezza, considerare sempre che il peso dello stampo deve essere sopportato da 2 soli perni.

Notes

Material: 42CrMo4 + QT

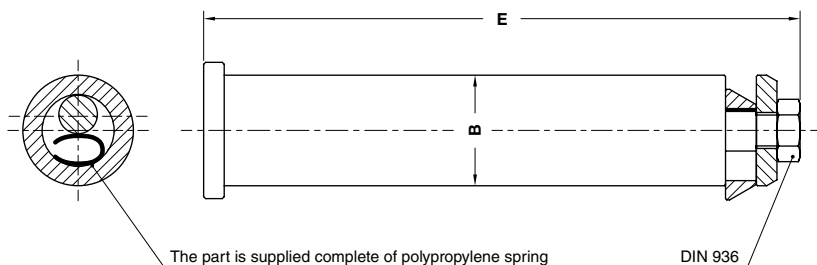

FCA CODE

SOL_KG26000_T_HL

FCA CODE	Max load (kg)	Max die weight (kg)	E	B
SOL_KG16000_T_HL	16000	32000	227	53
SOL_KG26000_T_HL	26000	52000	272,5	63

BUSH FOR LIFTING PIN - BUCHSE FÜR TRAGBOLZEN - BOCCOLA PER PERNO DI SOLLEVAMENTO

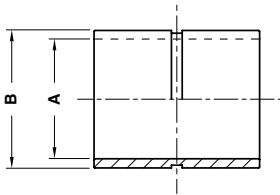
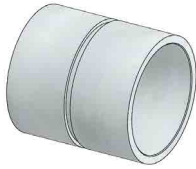

Notes

Material: S135

STOCK



WEB



COMMODITY CODE

19-232-0252

COMMODITY CODE	A	B
19-232-0200	52,4	60,33
19-232-0252	65,10	73,03
19-232-0320	82,50	92,08

Standard FCA

LIFTING BRACKET WITH LIFTING BOLT
TRAGWANGE MIT TRAGBOLZEN MIT FALLRINGSICHERUNG
STAFFA DI SOLLEVAMENTO COMPLETA DI PERNO

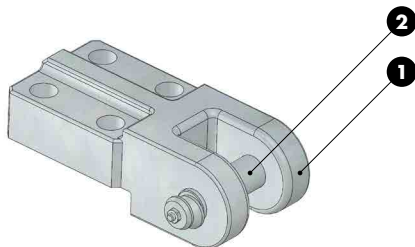

FORM A

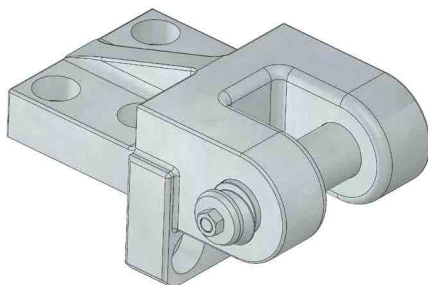

FORM B



Respect the max load
 Maximale Nutzlast beachten
 Rispettare il carico Max

WARNING - ACHTUNG - ATTENZIONE:
 For safety reason, please consider always that the weight of the die has to be supported by just 2 lifting brackets.

Aus Sicherheitsgründen stets berücksichtigen, dass zwei Tragwagen das gesamte Werkzeuggewicht tragen müssen.

Per ragioni di sicurezza, considerare sempre che il peso dello stampo deve essere sopportato da 2 sole staffe.

Notes

① **Material:** CK45 - 800÷1000 N/mm²

② **Material:** CK45

Screws not included



FCA CODE
 GR_ST_KG1000

FCA CODE	Max load (kg)	Max die weight (kg)	FORM	LIFTING BRACKET	LIFTING BOLT
GR_ST_KG600	600	1200	A	ST_KG600_S	ST_KG600_P
GR_ST_KG1000	1000	2000	A	ST_KG1000_S	ST_KG1000_P
GR_ST_KG2000	2000	4000	A	ST_KG2000_S	ST_KG2000_P
GR_ST_KG4000	4000	8000	B	ST_KG4000_S	ST_KG4000_P
GR_ST_KG7000	7000	14000	B	ST_KG7000_S	ST_KG7000_P

LIFTING BRACKET WITH PIN AND LOCATING PINS
TRAGWANGE MIT TRAGBOLZEN UND ZENTRIERBOLZEN
STAFFA DI SOLLEVAMENTO COMPLETA DI PERNO E CENTRAGGI

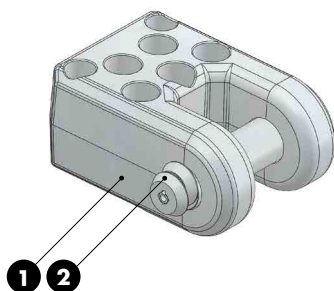
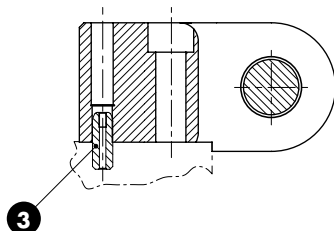

Respect the max load
 Maximale Nutzlast beachten
 Rispettare il carico Max

WARNING - ACHTUNG - ATTENZIONE:
 For safety reason, please consider always that the weight of the die has to be supported by just 2 lifting brackets.

Aus Sicherheitsgründen stets berücksichtigen, dass zwei Tragwagen das gesamte Werkzeuggewicht tragen müssen.

Per ragioni di sicurezza, considerare sempre che il peso dello stampo deve essere sopportato da 2 sole staffe.

Notes

- 1 Material:** St52
- 2 Material:** CK45
- 3 Material:** 16MnCr5 - HRC: 58÷60

Screws not included



WEB

WEB



FCA CODE
 ST_KG12500

FCA CODE	Max load (kg)	Max die weight (kg)	LIFTING BRACKET	LIFTING BOLT
ST_KG12500	12500	25000	ST_KG12500_S	ST_KG12500_P

REPLACEMENT LIFTING PIN FOR LIFTING BRACKET
ERSATZTRAGBOLZEN FÜR TRAGWANGE
PERNO DI RICAMBIO PER STAFFA DI SOLLEVAMENTO

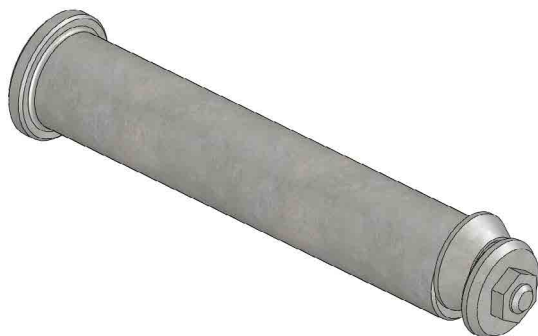

Respect the max load
 Maximale Nutzlast beachten
 Rispettare il carico Max

WARNING - ACHTUNG - ATTENZIONE:

For safety reason, please consider always that the weight of the die has to be supported by just 2 lifting pins.

Aus Sicherheitsgründen stets berücksichtigen, dass zwei Tragbolzen das gesamte Werkzeuggewicht tragen müssen.

Per ragioni di sicurezza, considerare sempre che il peso dello stampo deve essere sopportato da 2 soli perni.

Notes

Material: CK45



WEB

WEB

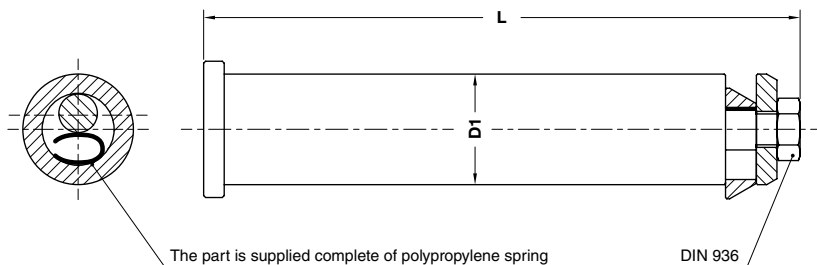

FCA CODE

ST_KG1000_P

FCA CODE	Max load (kg)	Max die weight (kg)	L	D1
ST_KG600_P	600	1200	102,5	15,6
ST_KG1000_P	1000	2000	113,5	20,6
ST_KG2000_P	2000	4000	128,5	25,6
ST_KG4000_P	4000	8000	166,5	33
ST_KG7000_P	7000	14000	210,5	43

REPLACEMENT LIFTING PIN FOR LIFTING BRACKET
ERSATZTRAGBOLZEN FÜR TRAGWANGE
PERNO DI RICAMBIO PER STAFFA DI SOLLEVAMENTO



Respect the max load
 Maximale Nutzlast beachten
 Rispettare il carico Max

WARNING - ACHTUNG - ATTENZIONE:

For safety reason, please consider always that the weight of the die has to be supported by just 2 lifting pins.

Aus Sicherheitsgründen stets berücksichtigen, dass zwei Tragbolzen das gesamte Werkzeuggewicht tragen müssen.

Per ragioni di sicurezza, considerare sempre che il peso dello stampo deve essere sopportato da 2 soli perni.

Notes

Material: CK45



WEB



STOCK



WEB

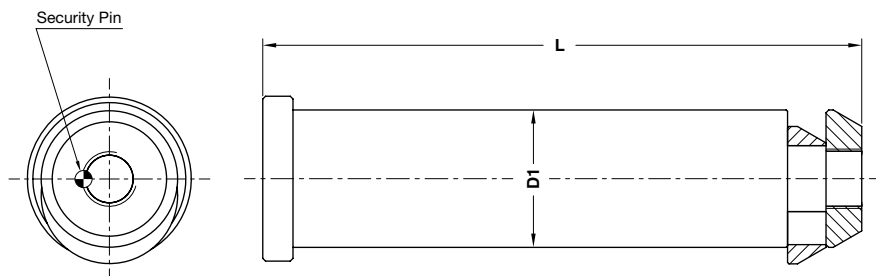

FCA CODE

ST_KG12500_P

FCA CODE	Max load (kg)	Max die weight (kg)	L	D1
ST_KG12500_P	12500	25000	246	60

WEAR PLATE SELF-LUBRICATING GLEITPLATTE BRONZE MIT FESTSCHMIERSTOFF PIASTRA GUIDA AUTOLUBRIFICANTE

Notes

Material: Bronze + Graphite -

Only for replacement

Nur für Reparatur

Solo per riparazione



WEB

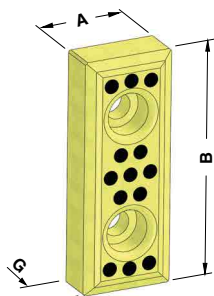

FORM A

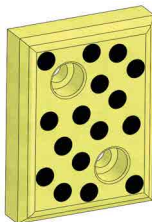

FORM B

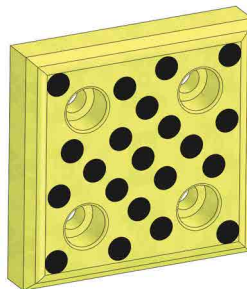

FORM C

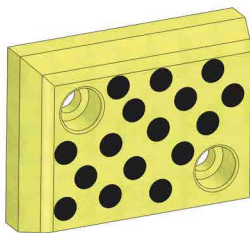

FORM D

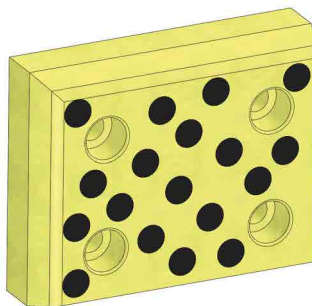

FORM E



FCA CODE

BR2

FCA CODE	A	B	G	FORM	FCA CODE	A	B	G	FORM
BR1	38	100	20	A	BR6	100	150	20	C
BR2	38	150	20	A	BR10	100	75	18	D
BR3	75	100	20	B	BR11	125	100	25	E
BR4	75	150	20	A	BR12	150	125	25	E
BR5	100	100	20	C					

WEAR PLATE STEEL
GLEITPLATTE STAHL
PIASTRA GUIDA IN ACCIAIO

Notes

Material: 16MnCr5 - HRC: 58÷60

Only for replacement

Nur für Reparatur

Solo per riparazione

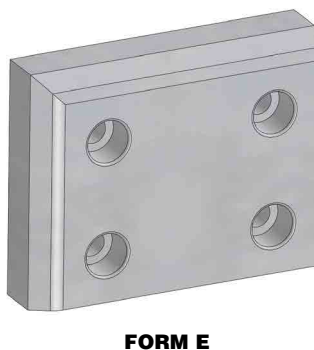
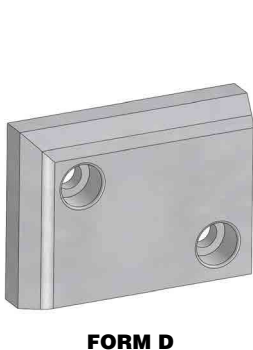
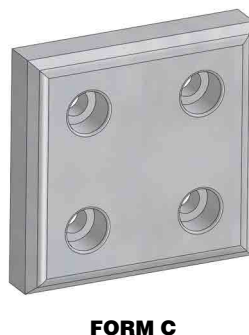
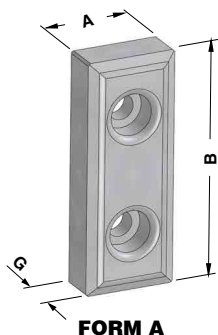
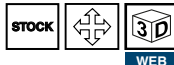

FCA CODE
ACC2

FCA CODE	A	B	G	FORM
ACC1	38	100	20	A
ACC2	38	150	20	A
ACC3	75	100	20	B
ACC4	75	150	20	A
ACC5	100	100	20	C

FCA CODE	A	B	G	FORM
ACC6	100	150	20	C
ACC10	100	75	18	D
ACC11	125	100	25	E
ACC12	150	125	25	E

Standard FCA

DISTANCE PLATE FOR WEAR PLATE HÖHEN AUSGLEICH FÜR GLEITPLATTE DISTANZIALE PER PIASTRA GUIDA

Notes

Material: Si37

Only for replacement

Nur für Reparatur

Solo per riparazione

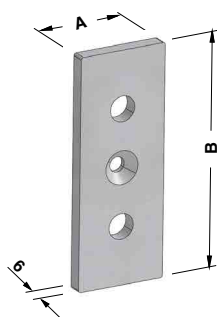

FORM A

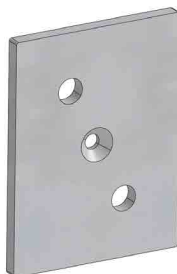

FORM B

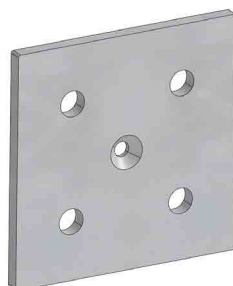

FORM C



FCA CODE

TIPO 2-S-B

FCA CODE	A	B	FORM	FCA CODE	A	B	FORM
TIPO 1-S-B	38	100	A	TIPO 6-S-B	100	150	C
TIPO 2-S-B	38	150	A	TIPO 10-S-B	100	75	B
TIPO 3-S-B	75	100	B	TIPO 11-S-B	125	100	C
TIPO 4-S-B	75	150	A	TIPO 12-S-B	150	125	C
TIPO 5-S-B	100	100	C				

GUIDE BAR SELF-LUBRICATING FÜHRUNGSLEITE BRONZE MIT FESTSCHMIERSTOFF LARDONE AUTOLUBRIFICANTE

FORM A

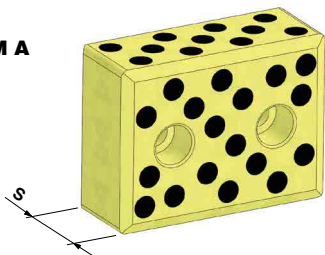

FORM B

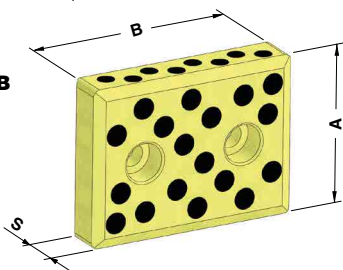

Notes

Material: Bronze + Graphite -

Only for replacement
Nur für Reparatur
Solo per riparazione

STOCK



WEB



FCA CODE

BR31

FCA CODE	A	B	S	FORM
BR30	48	100	20	B
BR31	48	150	20	B
BR32	75	100	20	B
BR33	75	150	20	B
BR7	75	100	38	A
BR8	75	150	38	A

Standard FCA

GUIDE BAR STEEL FÜHRUNGSLEITE STAHL LARDONE IN ACCIAIO

FORM A

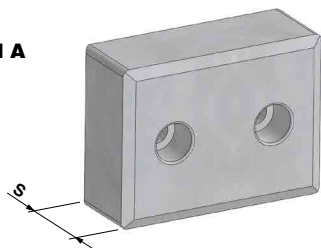

FORM B

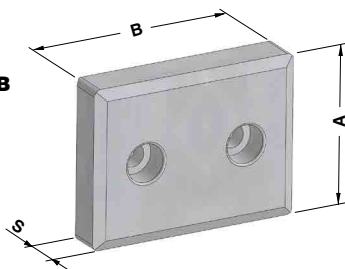

Notes

Material: 16MnCr5 - HRC: 58÷60

Only for replacement
Nur für Reparatur
Solo per riparazione

STOCK



WEB



FCA CODE

ACC31

FCA CODE	A	B	S	FORM
ACC30	48	100	20	B
ACC31	48	150	20	B
ACC32	75	100	20	B
ACC33	75	150	20	B
ACC7	75	100	38	A
ACC8	75	150	38	A

FRONT GAGE - EINLAUFANSCHLAG - PORTASENSORE

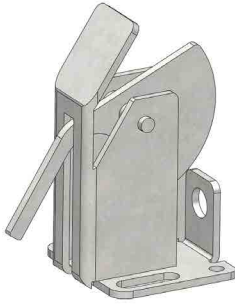

Notes

Material: Si37
 Only for replacement
 Nur für Reparatur
 Solo per riparazione



	FCA CODE	
	RIF_M18L150	
	FCA CODE	H2
	RIF_M18L120	117
	RIF_M18L150	142
	RIF_M18L180	192

BRACKET FOR CLAMPS - KLAMMERN FÜR CLAMPS - STAFFE PER CLAMPS

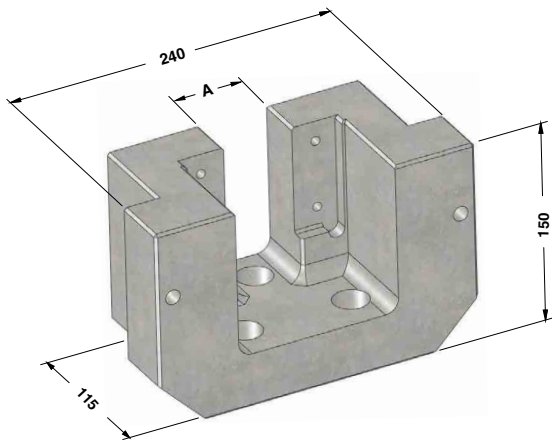

ST_S01

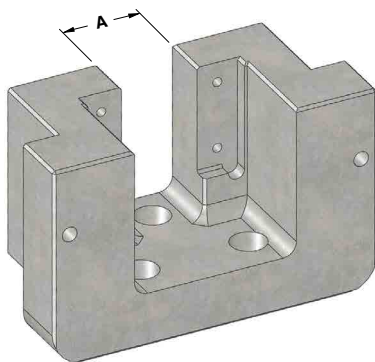

ST_S02

Notes

Material: 36CrNiMo4
950 ± 1000 N/mm²

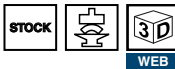

Application example*

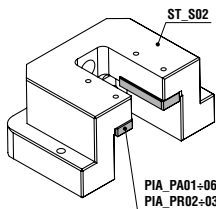
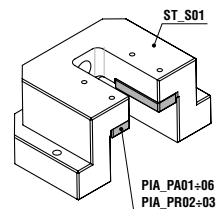

* See STD 10062
Sehen STD 10062
Vedi STD 10062

Standard FCA

	FCA CODE
	ST_S02

FCA CODE	A
ST_S01	51
ST_S02	56

PLATE FOR BRACKET - HALTESTÜCKE FÜR KLAMMERN - PIASTRINA PER STAFFE

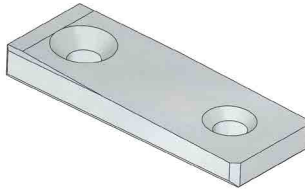

Notes

Material: 36CrNiMo4 - **HRC:** 50+52

STOCK



WEB



FCA CODE

PIA_PA01

FCA CODE

PIA_PA01

PLATE FOR BRACKET - HALTESTÜCKE FÜR KLAMMERN - PIASTRINA PER STAFFE

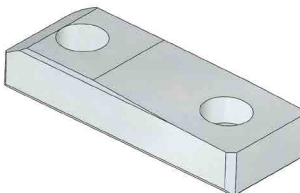

Notes

Material: 36CrNiMo4 - **HRC:** 50+52

STOCK



WEB



FCA CODE

PIA_PA02

FCA CODE

PIA_PA02

PLATE FOR BRACKET - HALTESTÜCKE FÜR KLAMMERN - PIASTRINA PER STAFFE

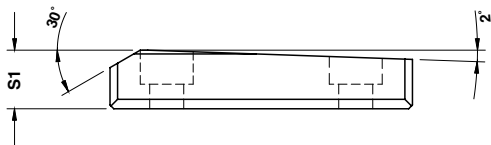

Notes

Material: 36CrNiMo4 · **HRC:** 50±52



	FCA CODE
	PIA_PA05
FCA CODE	S1
PIA_PA05	15.5
PIA_PA06	20.5

Standard FCA

PLATE FOR BRACKET - HALTESTÜCKE FÜR KLAMMERN - PIASTRINA PER STAFFE

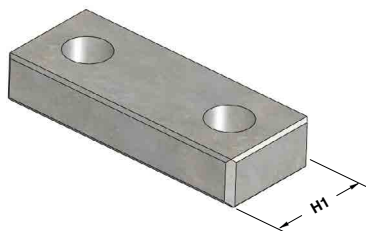

Notes

Material: 36CrNiMo4 · **HRC:** 50±52



	FCA CODE
	PIA_PR03
FCA CODE	H1
PIA_PR02	32.5
PIA_PR03	35

**VISUAL LOCATOR PUNCH
ENDKONTROLLSTEMPEL
PUNZONE DI VISUALIZZAZIONE**

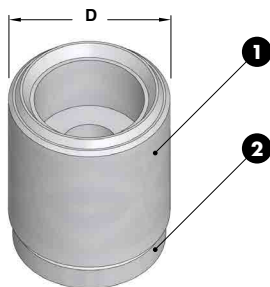

Notes

- 1 Material: X210Cr12 - HRC: 60÷62
- 2 Material: 42CrNiMo4



ORDER EXAMPLE	FCA CODE
	PFC_016

FCA CODE	D
PFC_012	13
PFC_016	19
PFC_018	25

LOCATING - ZENTRIERUNG - CENTRAGGIO STAMPO



Notes

Material: 36CrNiMo4



ORDER EXAMPLE	FCA CODE
	CNT_ST_01

FCA CODE
CNT_ST_01

STOP BLOCK - ANSCHLAG - FINE CORSA DIRITTO E A "V"



CTN_ST_02

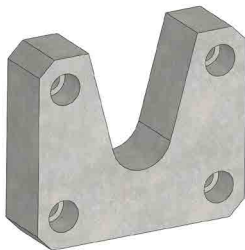

CTN_ST_03

Notes

Material: 36CrNiMo4



ORDER EXAMPLE	FCA CODE
	CTN_ST_03

FCA CODE
CTN_ST_02
CTN_ST_03

Standard FCA

KEY - PASSFEDER - CHIAVETTA DI REAZIONE

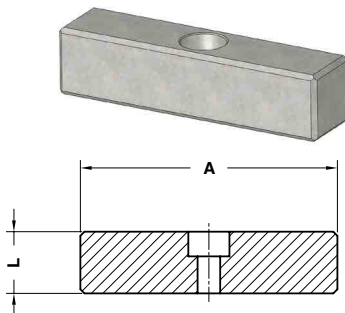

Notes

Material: CK45

ORDER EXAMPLE	FCA CODE
	CH_R_025125

FCA CODE	A	L
CH_R_025080	80	25
CH_R_025125	125	25
CH_R_030080	80	30
CH_R_030125	125	30



OMCR
STANDARD DIE COMPONENT