

CAM UNITS CLF
SCHIEBER CLF
CAMME CLF

OMCR CODE	Work Angle	Slider Width (mm)	Closed Cam Height (mm)	Work Area W x H (mm)	Max Work Force with shoulder 10 ⁶ cycles (kN)	Extraction Force (kN)
	β				F _s	F _f
CLF080	0÷70°	80	270	80x86	116	1,26÷2,72
CLF150	0÷70°	150	270	150x85	192	3,66÷7,25



Reliability in supplying

AERIAL CAM UNIT - OBEN HÄNGENDER SCHIEBER - UNITÀ A CAMME SOSPESA

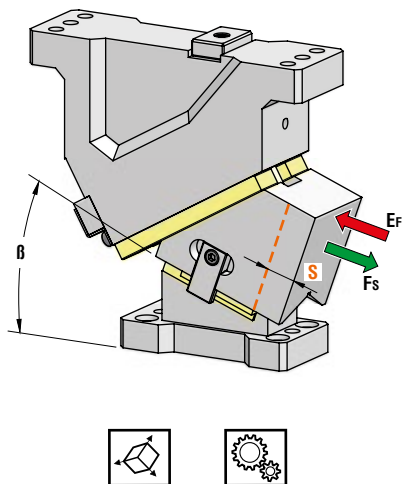

OMCR CODE	Work Angle	Stroke (mm)	Max Work Force with shoulder (kN)	Extraction Force (kN)
	β	S	Fs	Ef Spring
CLF080.00	0°	32,14	116	2,47
CLF080.05	5°	38,45	116	2,72
CLF080.10	10°	38,89	116	2,47
CLF080.15	15°	39,65	116	2,21
CLF080.20	20°	46,08	116	2,47
CLF080.25	25°	47,78	116	2,21
CLF080.30	30°	54,25	116	2,47
CLF080.35	35°	57,36	116	2,21
CLF080.40	40°	64,28	116	2,47
CLF080.45	45°	69,64	116	2,21
CLF080.50	50°	77,79	116	2,47
CLF080.55	55°	87,17	116	2,21
CLF080.60	60°	98,48	116	1,92
CLF080.65	65°	81,56	116	1,59
CLF080.70	70°	86,38	116	1,26

OPTION CODE

SL	1 ÷ 60 (1mm steps)
SW	100 or 120 mm
N	Ø16H7

OPTION CODE

Art.	Work Angle = 5°	OPTION CODE		
		SL	SW	N
CLF080	05	SL55	SW120	N16

OMCR CODE	Work Angle	Overall Dimensions (mm)				
	β	A	B	C	D	E
CLF080.00	0°	260	99	100	265	130
CLF080.05	5°	272,93	109,39	100	265	150
CLF080.10	10°	279,92	120,43	100	265	150
CLF080.15	15°	285,93	132,04	100	265	150
CLF080.20	20°	285,90	129,12	90	255	170
CLF080.25	25°	289,80	141,60	90	255	170
CLF080.30	30°	282,59	134,36	75	240	170
CLF080.35	35°	284,27	147,32	75	240	170
CLF080.40	40°	274,80	140,38	60	225	170
CLF080.45	45°	274,20	153,44	60	225	170
CLF080.50	50°	262,46	151,39	35	200	170
CLF080.55	55°	259,60	164,14	35	200	170
CLF080.60	60°	240,64	176,59	0	165	170
CLF080.65	65°	235,61	188,65	-5	160	170
CLF080.70	70°	227,83	195,53	-10	155	170

AERIAL CAM UNIT - OBEN HÄNGENDER SCHIEBER - UNITÀ A CAMME SOSPESA

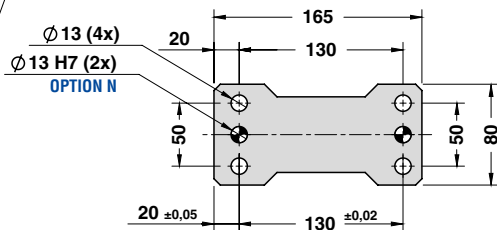
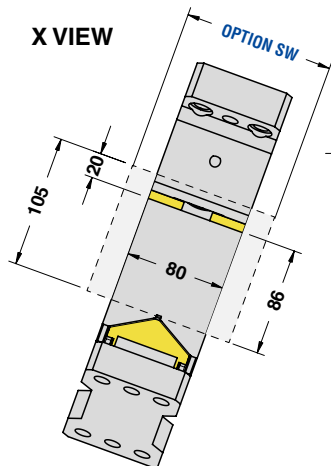

CAM DIAGRAM

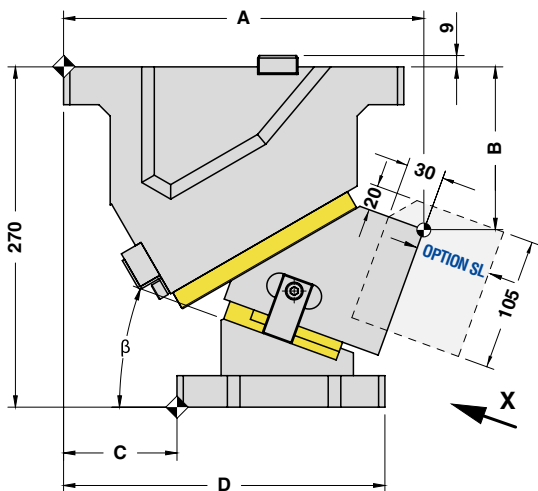
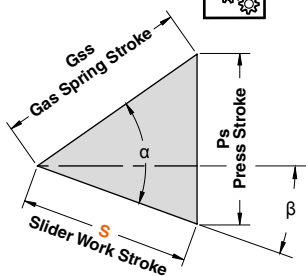

Work Angle	Inner Angle	Slider Work Stroke (mm)	Press Stroke (mm)	Gas Spring Stroke (mm)
β	α	S	Ps	Gss
0°	50°	32,14	38,30	50
5°	45°	38,45	35,49	50
10°	50°	38,89	38,89	50
15°	55°	39,65	42,40	50
20°	50°	46,08	40,76	50
25°	55°	47,78	45,19	50
30°	50°	54,25	44,23	50
35°	55°	57,36	50,00	50
40°	50°	64,28	50,00	50
45°	55°	69,64	57,92	50
50°	50°	77,79	59,59	50
55°	55°	87,17	71,41	50
60°	50°	98,48	76,60	50
65°	55°	81,56	67,84	35
70°	60°	86,38	75,96	30

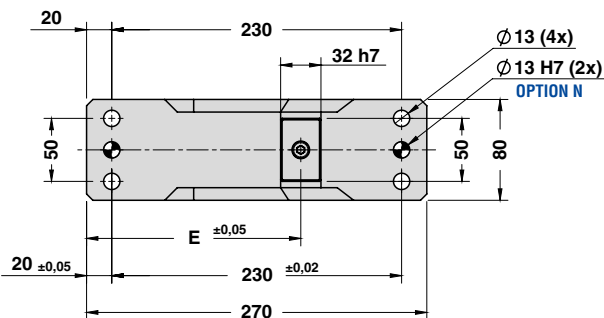

AERIAL CAM UNIT - OBEN HÄNGENDER SCHIEBER - UNITÀ A CAMME SOSPESA

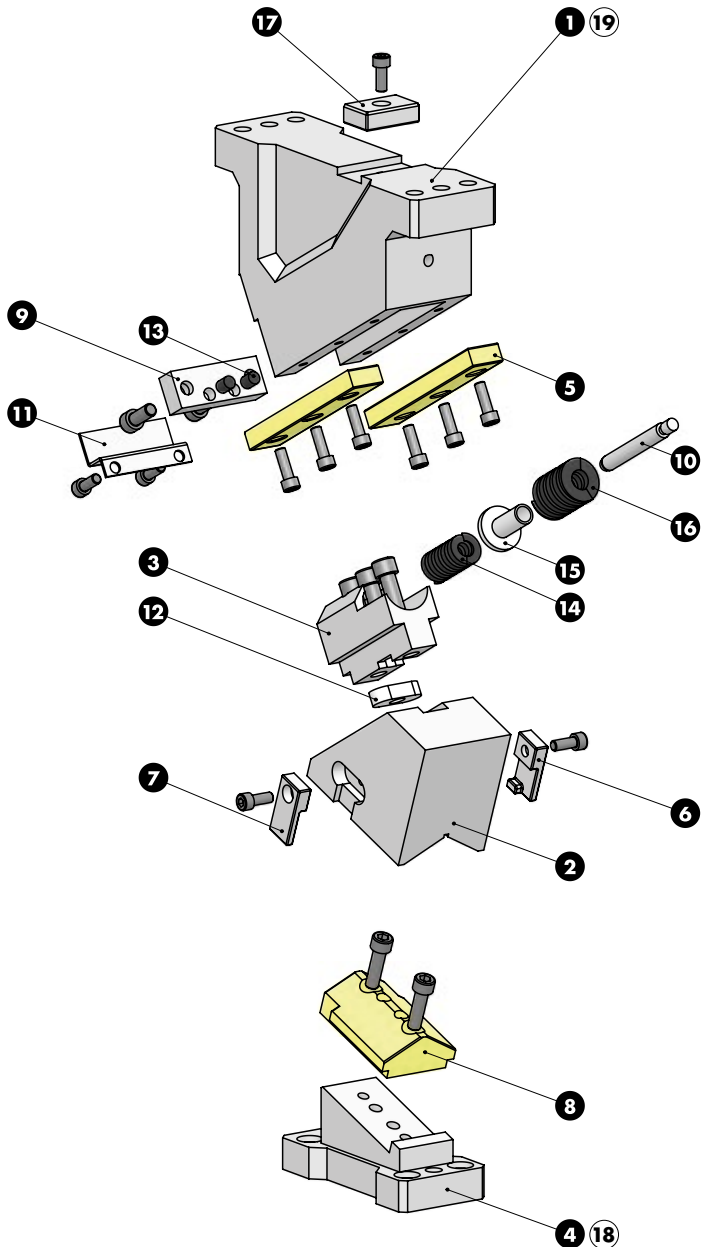

AERIAL CAM UNIT - OBEN HÄNGENDER SCHIEBER - UNITÀ A CAMME SOSPESA

SLIDER STRUCTURE, POSITIVE RETURN STRUCTURE AND CLEARANCES

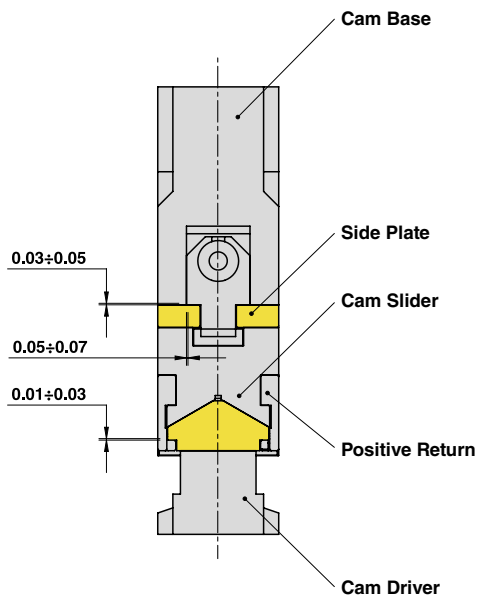

Particular number	Description	Material	Quantity
1	Cam Base	GGG-45	1
2	Cam Slider	GG-25	1
3	Spring Guide Block	GGG-45 + Graphite	1
4	Cam Driver	GG-25	1
5	Side Plate	CuZn25Al5 + Graphite - HB > 190	2
6	Positive Return R	CK45	1
7	Positive Return L	CK45	1
8	Male "V" Driver	CuZn25Al5 + Graphite - HB > 190	1
9	Stopper Plate	St44	1
10	Spring Guide Pin	34CrMo4	1
11	Safety Plate	St44	1
12	Key	CK45	1
13	Elastomer Cap	Elastomer 92SH	2
14	Spring	-	1
15	Spring Spacer	CK45	1
16	Spring	-	1
17	Key	CK45	1
18	Cam Driver Fixing Screws M12x40 DIN 912	-	4
19	Cam Base Fixing Screws M12x45 DIN 912	-	4

AERIAL CAM UNIT - OBEN HÄNGENDER SCHIEBER - UNITÀ A CAMME SOSPESA

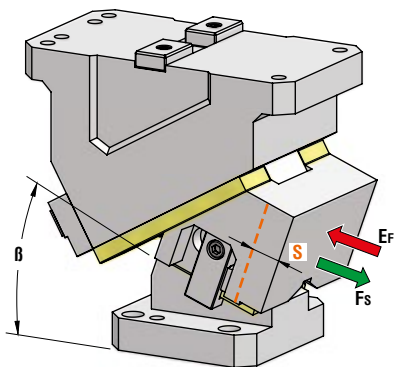

OMCR CODE	Work Angle	Stroke (mm)	Max Work Force with shoulder (kN)	Extraction Force (kN)
	β	S	F _s	E _f
CLF150.00	0°	32,14	192	7,25
CLF150.05	5°	32,26	192	6,47
CLF150.10	10°	38,89	192	7,25
CLF150.15	15°	39,65	192	6,47
CLF150.20	20°	46,08	192	7,25
CLF150.25	25°	47,78	192	6,47
CLF150.30	30°	54,25	192	7,25
CLF150.35	35°	57,36	192	6,47
CLF150.40	40°	64,28	192	7,25
CLF150.45	45°	69,64	192	6,47
CLF150.50	50°	77,79	192	7,25
CLF150.55	55°	87,17	192	6,47
CLF150.60	60°	98,48	192	5,64
CLF150.65	65°	93,21	192	4,64
CLF150.70	70°	86,38	192	3,66

OPTION CODE

N	∅16 H7
---	--------

OPTION CODE



Art.	Work Angle = 5°	N
CLF150	05	N16

OMCR CODE	Work Angle	Overall Dimensions (mm)				
	β	A	B	C	D	E
CLF150.00	0°	280	85	120	270	100
CLF150.05	5°	288,26	95,84	115	265	100
CLF150.10	10°	285,54	102,36	105	255	100
CLF150.15	15°	291,79	114,47	105	255	100
CLF150.20	20°	286,97	122,07	90	240	135
CLF150.25	25°	291,02	135,08	90	240	135
CLF150.30	30°	283,92	138,40	70	220	135
CLF150.35	35°	285,66	151,91	70	220	135
CLF150.40	40°	276,20	155,53	45	195	170
CLF150.45	45°	275,56	169,14	45	195	170
CLF150.50	50°	263,74	167,65	25	175	170
CLF150.55	55°	260,74	180,94	25	175	170
CLF150.60	60°	246,60	193,92	0	150	170
CLF150.65	65°	241,35	206,49	0	150	170
CLF150.70	70°	240,01	218,56	-5	145	170

AERIAL CAM UNIT - OBEN HÄNGENDER SCHIEBER - UNITÀ A CAMME SOSPESA

X VIEW

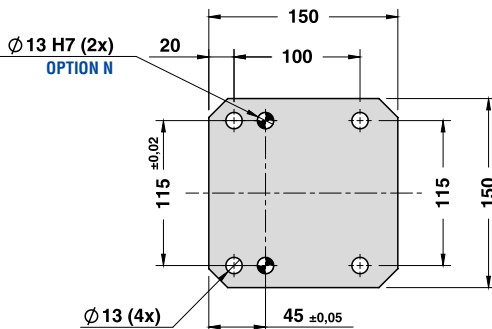
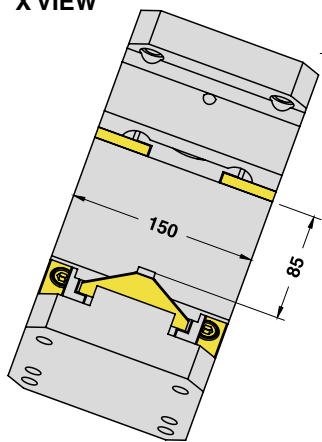

CAM DIAGRAM

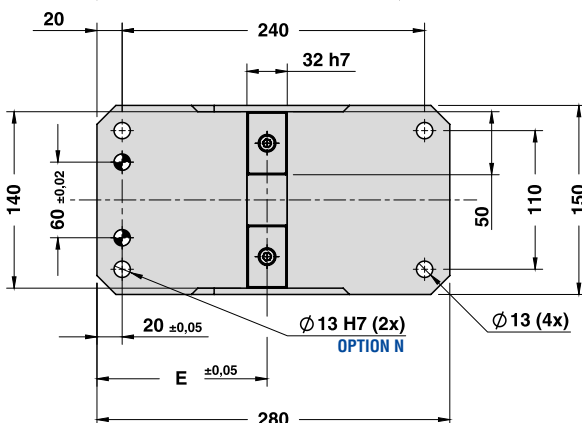
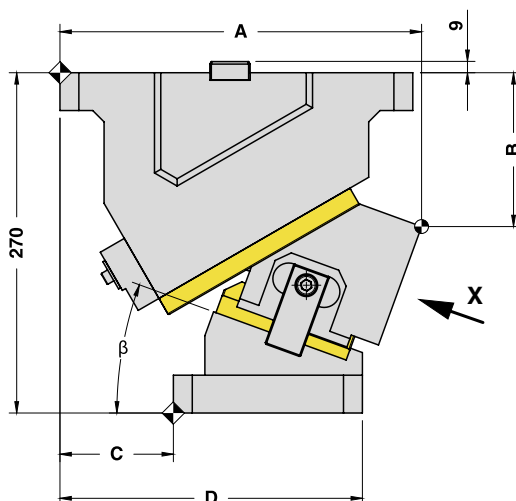
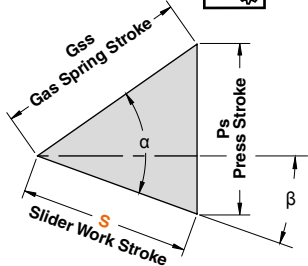

Work Angle	Inner Angle	Slider Work Stroke (mm)	Press Stroke (mm)	Gas Spring Stroke (mm)
β	α	S	Ps	Gss
0°	50°	32,14	38,30	50
5°	45°	32,26	41,11	50
10°	50°	38,89	38,89	50
15°	55°	39,65	42,40	50
20°	50°	46,08	40,76	50
25°	55°	47,78	45,19	50
30°	50°	54,25	44,23	50
35°	55°	57,36	50,00	50
40°	50°	64,28	50,00	50
45°	55°	69,64	57,92	50
50°	50°	77,79	59,59	50
55°	55°	87,17	71,41	50
60°	50°	98,48	76,60	50
65°	55°	93,21	77,53	40
70°	60°	86,38	75,96	30

Cam Units CLF

AERIAL CAM UNIT - OBEN HÄNGENDER SCHIEBER - UNITÀ A CAMME SOSPESA

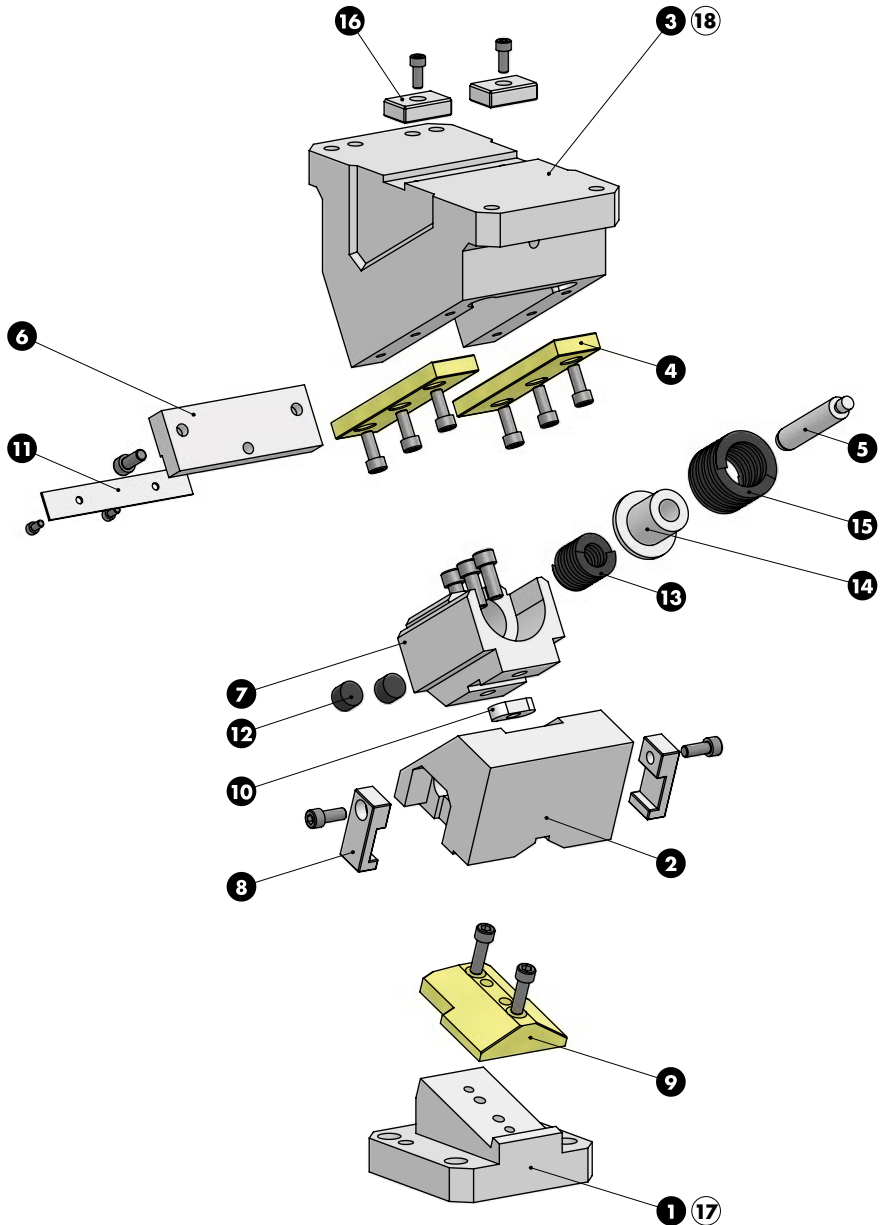

AERIAL CAM UNIT - OBEN HÄNGENDER SCHIEBER - UNITÀ A CAMME SOSPESA

SLIDER STRUCTURE, POSITIVE RETURN STRUCTURE AND CLEARANCES

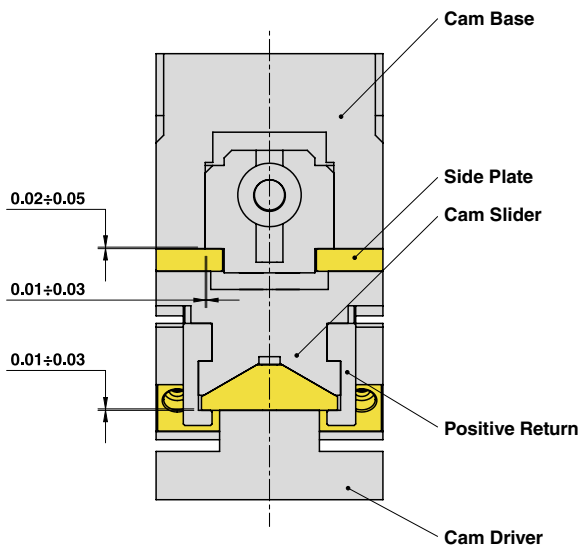

Particular number	Description	Material	Quantity
1	Cam Driver	GG-25	1
2	Cam Slider	GG-25	1
3	Cam Base	GG-25	1
4	Side Plate	CuZn25Al5 + Graphite - HB > 190	2
5	Spring Guide Pin	34CrMo4	1
6	Stopper Plate	St44	1
7	Spring Guide Block	GGG-45 + Graphite	1
8	Positive Return	CK45	2
9	Male "V" Driver	CuZn25Al5 + Graphite - HB > 190	1
10	Key	CK45	1
11	Safety Plate	St44	1
12	Elastomer Cap	Elastomer 92SH	2
13	Spring	-	1
14	Spring Spacer	CK45	1
15	Spring	-	1
16	Key	CK45	2
17	Cam Driver Fixing Screws M12x45 DIN 912	-	4
18	Cam Base Fixing Screws M12x45 DIN 912	-	4